

New  
3-Stage High Torque model TPMA 025-110



# TPM

Servo actuators - Setting new standards in dynamics, precision and compactness

6



10



## Overview WITTENSTEIN group

4 - 5

## TPM product features, applications

6 - 9

Design properties & features

## TPM series 004 - 110

10 - 29

Technical data, characteristic curves and drawings

## TPMA series 025 - 110

30 - 41

Technical data, characteristic curves and drawings

## Options and accessories

42 - 44

Brake, temperature sensors, feedback systems, cables

## Servo controllers, plug connections

45 - 46

## Ordering codes

47

# Overview - WITTENSTEIN group

## WITTENSTEIN AG



The **WITTENSTEIN AG**, with its 750 employees worldwide, develops, produces and distributes high-precision planetary gears, entire electro-mechanical drive systems, as well as AC servo systems and motors, amongst other products. Areas of application include industrial robots, machine tools and packaging machines, paper and printing machines, elevators, the Formula 1, as well as the aerospace industry.

Technological competence and ongoing innovation ensure the success of the **WITTENSTEIN AG**. Creative and motivated employees are the basis of the company's acclaim. In the past two fiscal years, more than 200 new employees have joined the company. The turnover yielded by products that are less than 5 years old amounts to approx. 85 percent. Every tenth Euro is invested in research and development, more than 12 percent of the employees work in these fields.



Technical solutions: Customer benefit in the foreground



**alpha getriebebau GmbH**  
Low-backlash servo gears, planetary windlasses with integrated servo drives, as well as the servo design software cymex®.



**WITTENSTEIN motion control GmbH**  
Integrated electro-mechanical, rotative and linear servo systems. Intelligent units with the highest precision and dynamics.



**WITTENSTEIN cyber motor GmbH**  
Development and distribution of mini AC servomotors for industrial applications. Characteristics: Highest power density and reliability.



Company premises in Igersheim/Harthausen: Inspiration for innovation



750 motivated employees: Enthusiasm and emotion



**WITTENSTEIN**  
**intens** GmbH

Development, manufacture, sale and distribution of intelligent, innovative implants for orthopedic and accident surgery.



**WITTENSTEIN**  
**bastian** GmbH

Development, manufacture, sales and distribution of innovative gear technology. Implemented in, for example, the Formula 1 and the aerospace industry.



**WITTENSTEIN**  
**aerospace & simulation** GmbH

Development, manufacture, sales and distribution of electro-mechanical control systems, active control units for aeronautical applications and haptic systems with force feedback for simulators.

# Product features

With the TPM and TPMA AC servo actuators, the **WITTENSTEIN motion control** GmbH is providing the drive technology market with products that set new standards in precision, dynamics, power density and compactness.

Resolver feedback is standard. Optional single- or multi-turn absolute feedbacks with EnDat® (Heidenhain) or Hiperface® (Stegmann) interfaces available.

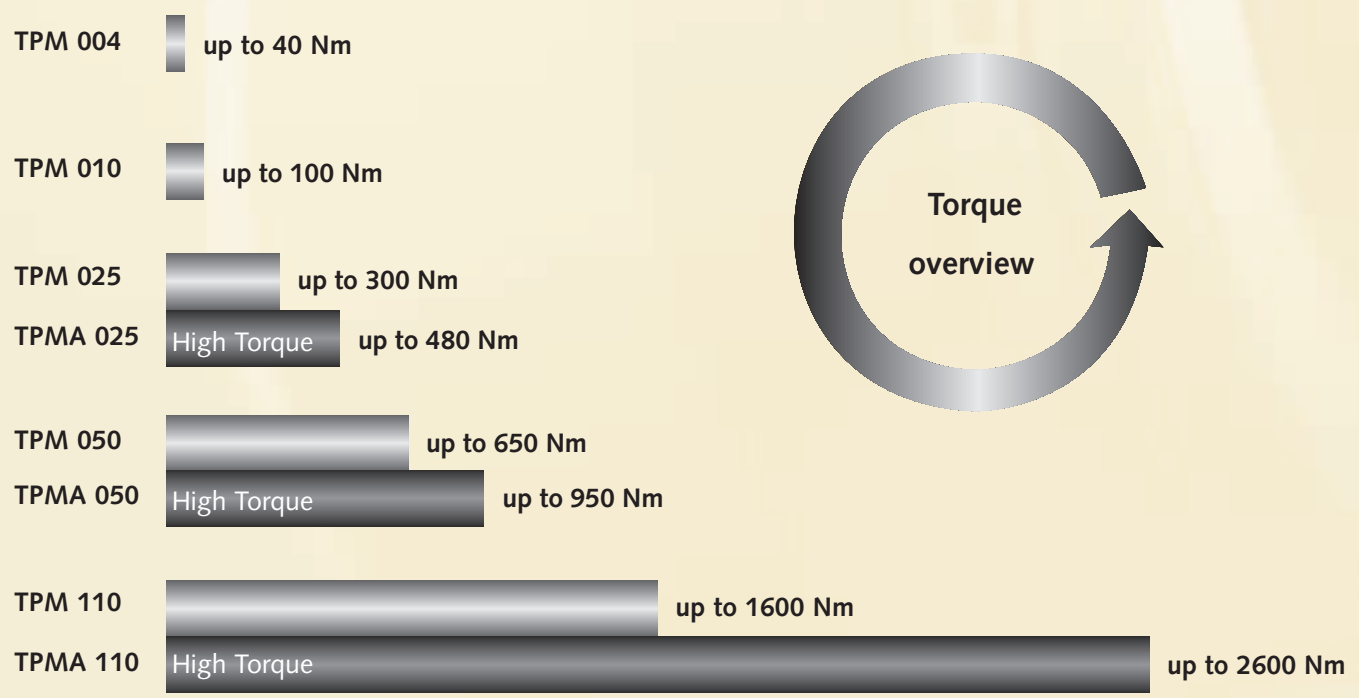
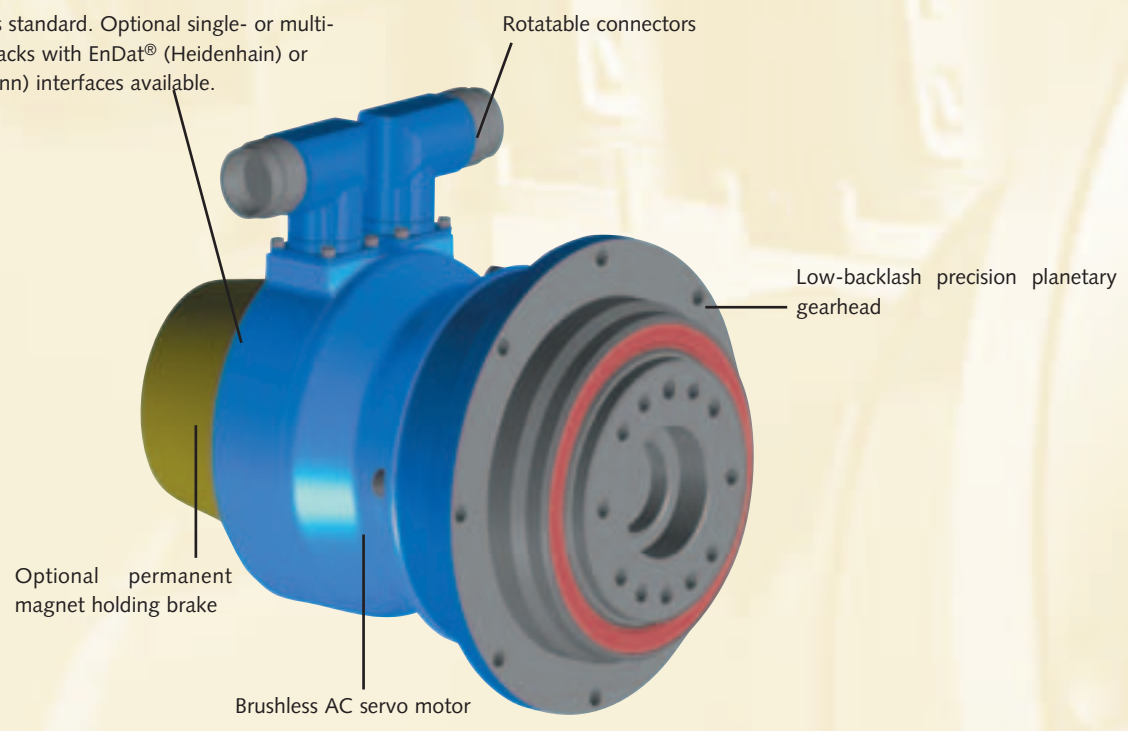

# Product features



## High dynamic performance

An integral brushless AC servomotor was designed to work with the alpha planetary gearheads to provide a high torque-to-inertia ratio, optimized for high dynamic performance. Connecting the motor to the gearhead without a coupling improves the stiffness of the unit while reducing the moment of inertia by approximately 40% compared to customary motor/gearhead units.

## High power density

A high pole count motor optimizes use of the magnetic material and yields the most power in the smallest package. In the new 3-stage TPMA version, the torque range has been considerably extended while maintaining the same compact design.

## Compact design/reduced weight

Integrating the servomotor and gearhead into one package sets new standards for reduced size and weight. It is approximately 62% shorter and weighs much less than a traditional motor/gearhead combination of comparable power. This is especially important for applications where mounting space is limited or where the motor itself is part of the moving load, e.g. robotics and gantries.

## High positioning accuracy/efficiency

Directly mounting the drive elements to the output flange reduces overall size and provides high torsional rigidity and short settling times. The pinion is integrated directly into the motor shaft, resulting in a much shorter motor-to-pinion distance. This design results in much higher positioning accuracy - <1 arc minute of backlash - and higher dynamics, for shorter cycle times and reduced production costs for the customer application. In addition, the TPM/TPMA feature overall efficiency >85%.

## Direct mount/reduced components

The TPM/TPMA can be mounted from either the front or the rear of the mounting flange. The application load mounts directly to the driving flange, eliminating the need for a coupling. Dual tapered roller bearings in the output stage (from size 050) eliminate the need for additional support bearings in the customer application. In addition, two swiveling connectors allow for easy cable routing.

## Maintenance free

High quality synthetic lubricants provide lubrication for the service life of the product.

## Smooth motion and quiet operation

The TPMs are characterized by low torque ripple for extremely smooth operation. They feature low noise levels of less than 65 dB(A).

## Simple integration

The TPM can be operated with most of the brushless servo controllers on the market. Preassembled cables and controller-specific start-up instructions simplify installation and start-up.

## Optional absolute feedback

An optional single- or multi-turn absolute encoder eliminates the necessity for homing on start-up.

# Applications



Yxlon



Six TPM drives on two swivel axes and one rotating axis control an X-ray testing system for cast parts. A move to a new position and an X-ray inspection occur within one second, repeating up to 300 times per part. The rapid positioning and testing procedure requires short settling times, which are achieved because of the low weight, high torsional rigidity and low inertia of the TPM drives.



Unicor

A winding unit without dancer roll forms the terminating unit of an extrusion machine for 2-5 mm wide plastic strips. Constant tension is required for smooth winding of the stripes. The high torsional rigidity and excellent dynamics of the TPM drive enables rapid torque regulation, within an torque-adjustment range of 1:40.



# Applications



SIG Robotics

Three TPM drives control the movement of the three axes of this fast pick and place robot, with up to 120 pick and place cycles per minute. The TPM was chosen for this application because of its high dynamic performance, low weight, small overall length and high reliability.



Gasti

Installed in a plant for dosing liquid products, three TPM drives control the piston dosing pump, a rotary valve and the container-lifting device. Because of its compact design, three TPM drives are incorporated into a 50 cm x 50 cm x 75 cm space.

# TPM 004 - Technical data, characteristic curves and drawings

## Gearhead data

Ratio	i			21, 31, 61, 91
Max. acceleration torque <sup>1)</sup>	$T_{2B}$	Nm	i = 31 i = 21, 61, 91	40 32
Emergency Stop torque <sup>2)</sup>	$T_{2Not}$	Nm		100
Nominal output torque	$T_{2N}$	Nm	i = 31 i = 21, 61, 91	25 15
Max. input speed	$n_{1Max}$	min <sup>-1</sup>		7,000
Nominal input speed <sup>3)</sup>	$n_{1N}$	min <sup>-1</sup>		6,000
Torsional backlash	$j_t$	arcmin	Standard Reduced	≤ 5 ≤ 3
Torsional rigidity	$C_{t21}$	Nm/arcmin		6.8
Max. axial force <sup>4)</sup>	$F_{2AMax}$	N		1,630
Max. tilting torque	$M_{2TiltMax}$	Nm		91
Tilting rigidity	$C_{2K}$	Nm/arcmin		85
No-load running torque ( $n_1 = 3000 \text{ min}^{-1}$ ) <sup>5)</sup>	$T_{012}$	Nm	i = 31 i = 91	0.15 0.08
Moment of inertia reflected to the input	$J_{Gear}$	kgcm <sup>2</sup>	i = 21 i = 31 i = 61 i = 91	0.01 0.01 0.001 0.001

## Motor data

			i = 21, 31	i = 61, 91
DC bus voltage	$U_D$	VDC	320	320
Peak torque <sup>6)</sup>	$M_{Max}$	Nm	1.70	0.79
Continuous stall torque	$M_0$	Nm	0.58	0.31
Nominal torque	$M_N$	Nm	0.48	0.25
Peak current <sup>6)</sup>	$I_{Max}$	A	4.20	2.90
Nominal current	$I_N$	A	1.30	1.00
No-load speed <sup>6)</sup>	$n_0$	min <sup>-1</sup>	9,100	13,500
Nominal speed <sup>6)</sup>	$n_N$	min <sup>-1</sup>	7,625	11,100
Max. power	$P_{Max}$	kW	0.92	0.58
Moment of inertia with resolver	$J_{Mot.}$	kgcm <sup>2</sup>	0.16	0.09

## General data

Protection class		IP64
Permissible transmission temperature	°C	-10 to +90
Mounting position		Any
Lubrication		Synthetic oil, ISO VG 220
Paint		RAL 5002 (Blue)
Noise level ( $n_1 = 3000 \text{ min}^{-1}$ )	dB(A)	≤ 65
Weight without/with brake	kg	2.6/3.0 at i = 21/31   2.4/2.7 at i = 61/91
Direction of rotation		motor and gearhead in same direction
Insulation class		F

1) 1000 cycles per hour

2) Permissible 1000 times during the life span of the gearhead

3) At 20°C ambient temperature

4) Based on the flange center

5) At 20°C gearhead temperature

6) Limit motor values to maximum values of the gearhead



The maximum and nominal values of the gearhead can limit the output values in some circumstances.

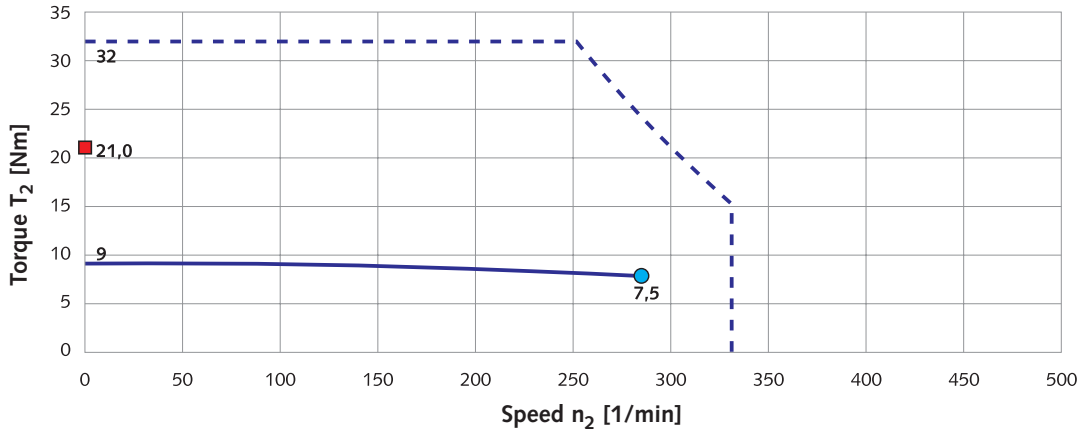

$i = 21$

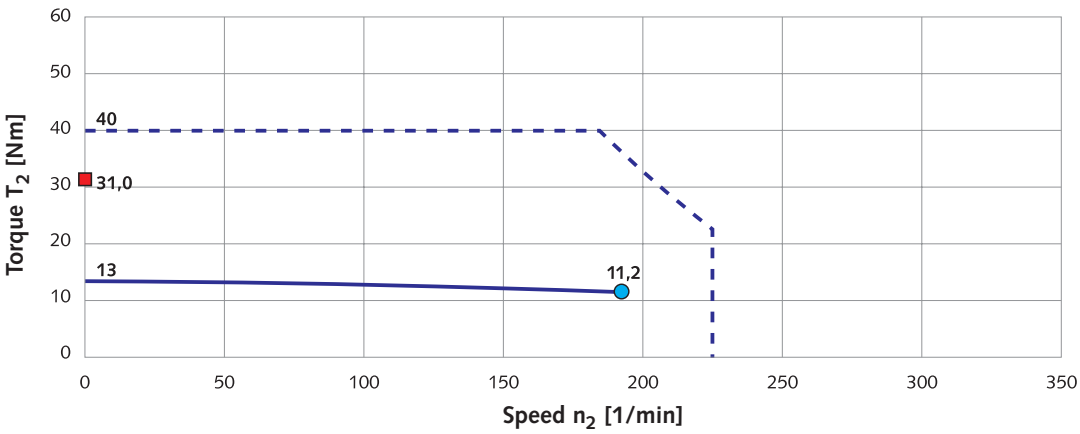

$i = 31$

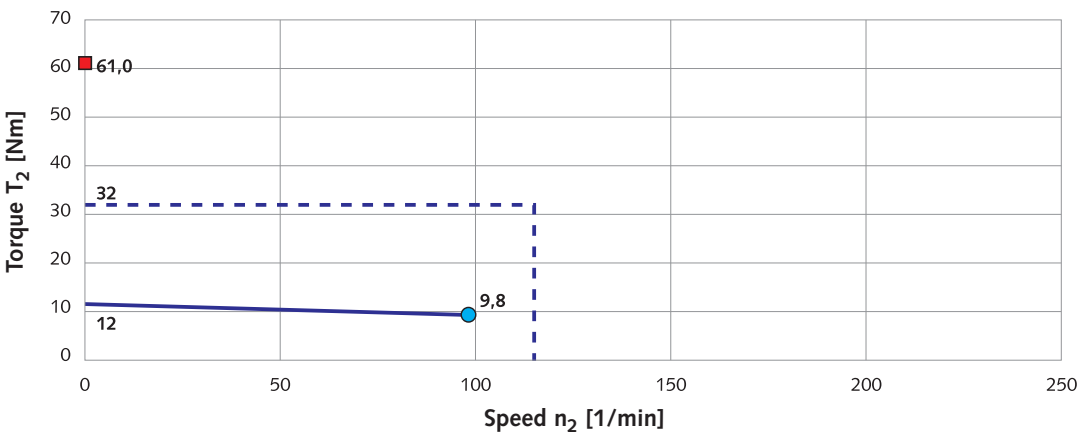

$i = 61$

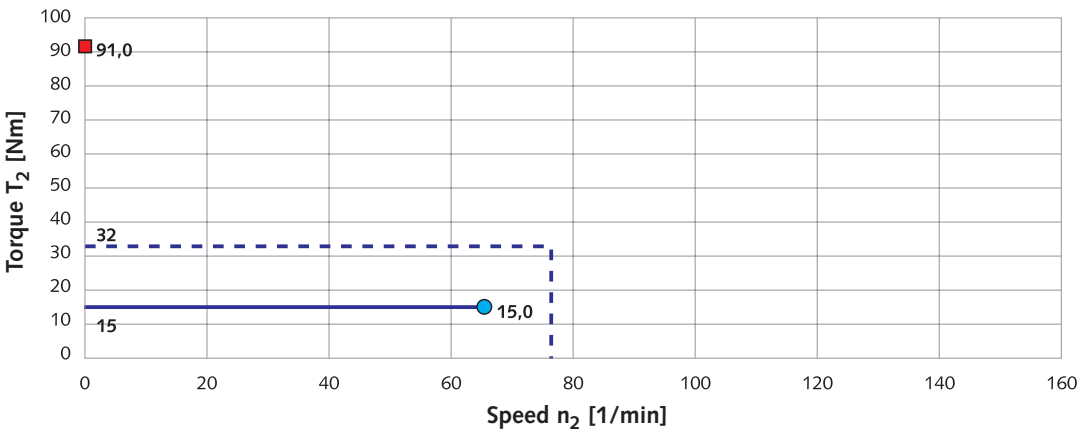

$i = 91$

- Max. output torque 320V DC
- Max. output torque 600V DC
- Nominal torque 320V DC
- Nominal torque 600V DC
- Holding torque: brake
- Nominal point 320V DC



Standard version with resolver **without**  
brake at  $i = 21/31$

TPM 004-...R-...-OH.-030

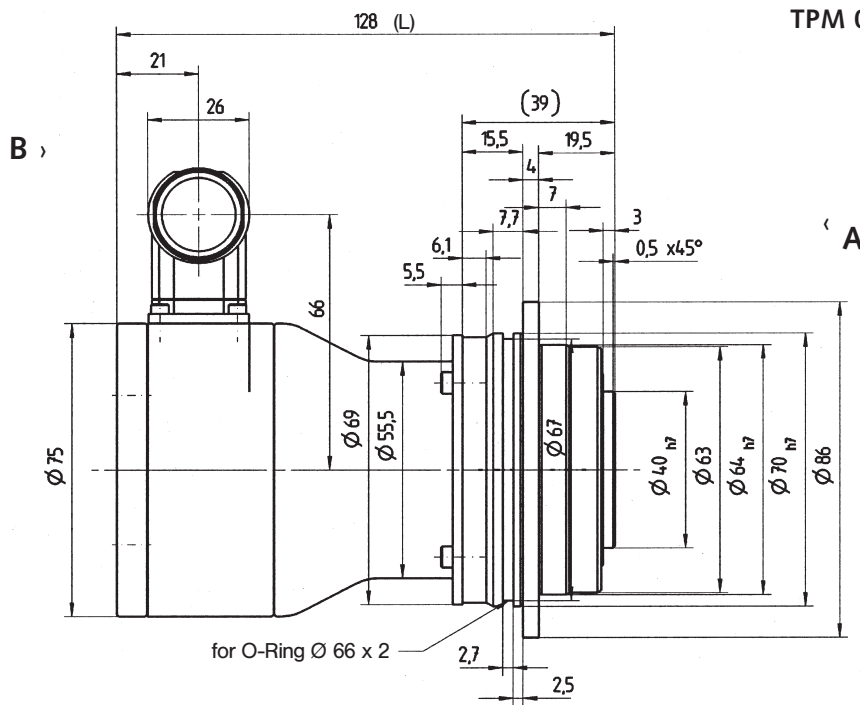

View A

Total length L for other options		
TPM 004, $i = 21, 31$	Without brake	With brake
Heidenhain motor encoder	-	-
Stegmann motor encoder	157	200

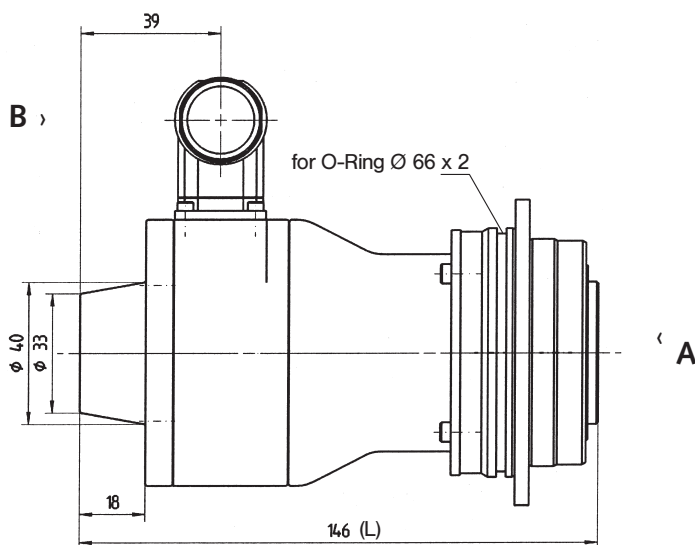
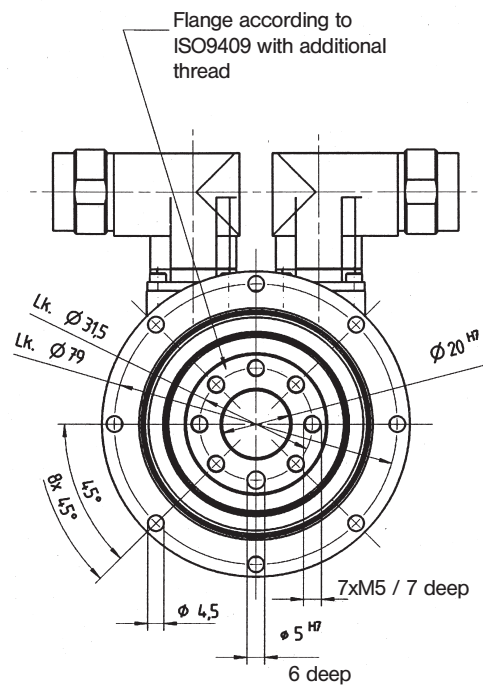

Standard version with resolver **with** brake  
at  $i = 21/31$

TPM 004-...R-...-BP.-030

Standard version with resolver **without**  
brake at  $i = 61/91$

TPM 004-...R-...-OH.-015

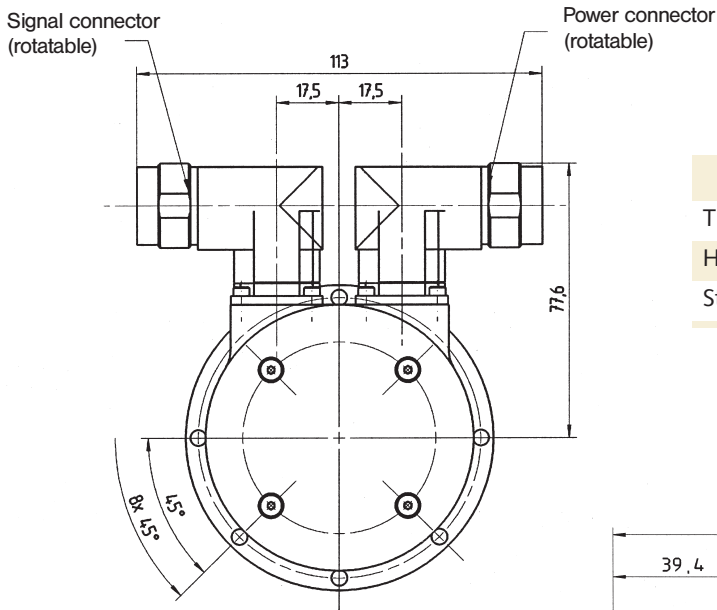
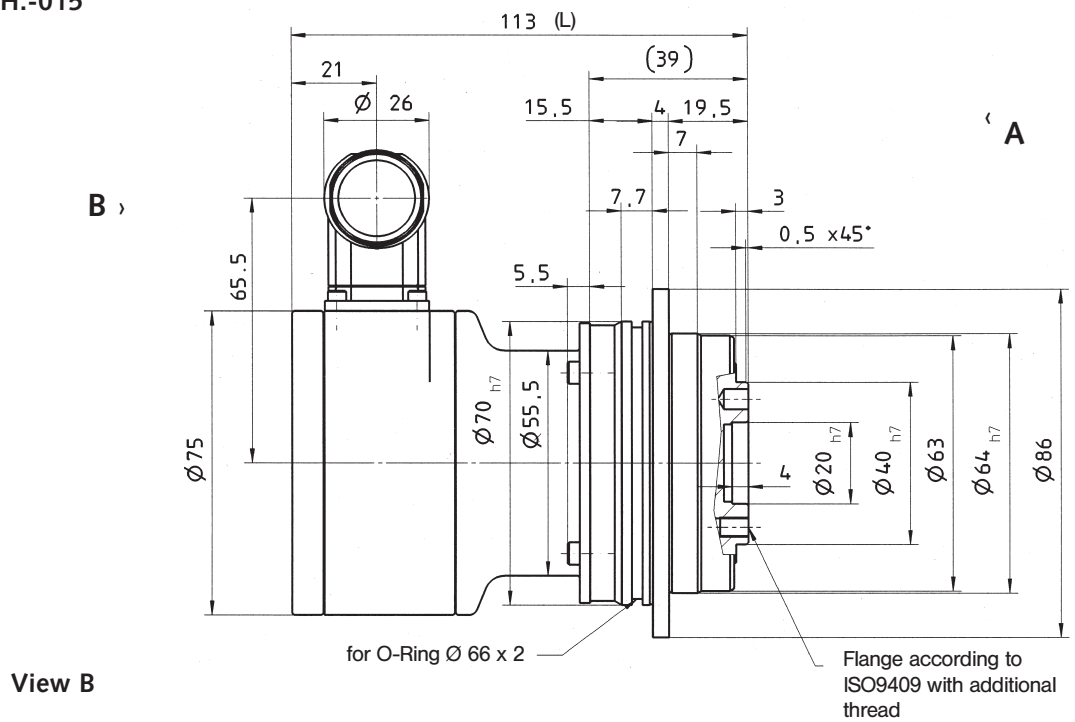

**Total length L for other options**

	Without brake	With brake
TPM 004, $i = 61, 91$	-	-
Heidenhain motor encoder	-	-
Stegmann motor encoder	142	185

Standard version with resolver **with**  
brake at  $i = 61/91$

TPM 004-...R-...-BP.-015

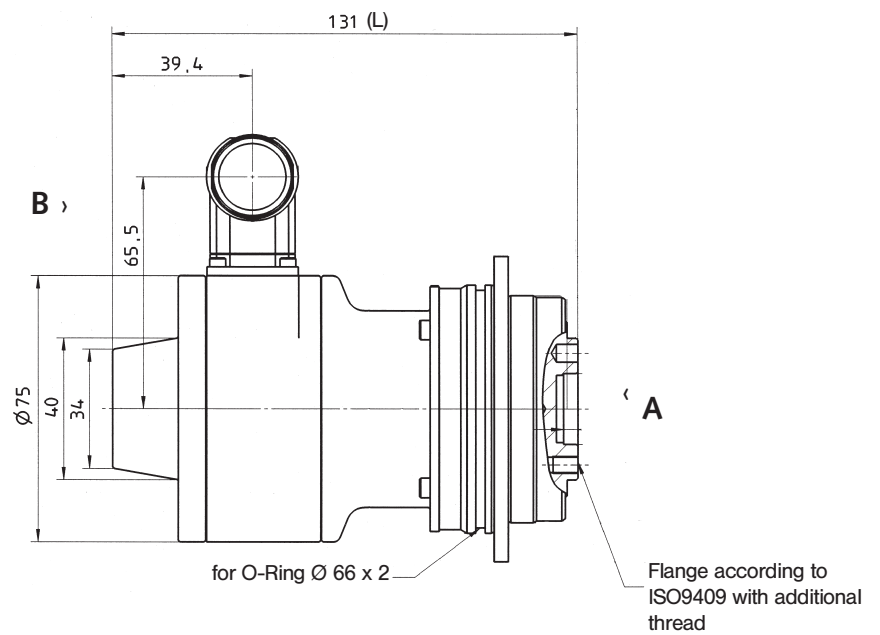

# TPM 010 - Technical data, characteristic curves and drawings

## Gearhead data

Ratio	i			21, 31, 61, 91
Max. acceleration torque <sup>1)</sup>	$T_{2B}$	Nm	i = 31 i = 21, 61, 91	100 80
Emergency Stop torque <sup>2)</sup>	$T_{2Not}$	Nm		250
Nominal output torque	$T_{2N}$	Nm	i = 31 i = 21, 61, 91	50 35
Max. input speed	$n_{1Max}$	min <sup>-1</sup>		7,000
Nominal input speed <sup>3)</sup>	$n_{1N}$	min <sup>-1</sup>		6,450
Torsional backlash	$j_t$	arcmin	Standard Reduced	≤ 3 ≤ 1
Torsional rigidity	$C_{t21}$	Nm/arcmin		21
Max. axial force <sup>4)</sup>	$F_{2AMax}$	N		2,150
Max. tilting torque	$M_{2TiltMax}$	Nm		235
Tilting rigidity	$C_{2K}$	Nm/arcmin		225
No-load running torque ( $n_1 = 3000 \text{ min}^{-1}$ ) <sup>5)</sup>	$T_{012}$	Nm	i = 31 i = 91	0.3 0.2
Moment of inertia reflected to the input	$J_{Gear}$	kgcm <sup>2</sup>	i = 21 i = 31 i = 61 i = 91	0.04 0.03 0.01 0.01

## Motor data

			i = 21, 31		i = 61, 91	
DC bus voltage	$U_D$	VDC	320	600	320	600
Peak torque <sup>6)</sup>	$M_{max}$	Nm	3.60	3.30	1.70	1.70
Continuous stall torque	$M_0$	Nm	1.10	1.10	0.60	0.60
Nominal torque	$M_N$	Nm	0.94	0.84	0.52	0.51
Peak current <sup>6)</sup>	$I_{Max}$	A	7.30	5.00	4.50	3.00
Nominal current	$I_N$	A	1.50	1.10	1.10	0.70
No-load speed <sup>6)</sup>	$n_0$	min <sup>-1</sup>	5,800	7,800	7,000	7,700
Nominal speed <sup>6)</sup>	$n_N$	min <sup>-1</sup>	4,875	6,775	5,900	6,550
Max. power	$P_{Max}$	kW	1.22	1.66	0.75	0.85
Moment of inertia with resolver	$J_{Mot.}$	kgcm <sup>2</sup>	0.37		0.21	

## General data

Protection class		IP64
Permissible transmission temperature	°C	-10 to +90
Mounting position		Any
Lubrication		Synthetic oil, ISO VG 220
Paint		RAL 5002 (Blue)
Noise level ( $n_1 = 3000 \text{ min}^{-1}$ )	dB(A)	≤ 65
Weight without/with brake	kg	4.9/5.3 at i = 21/31   4.4/4.9 at i = 61/91
Direction of rotation		motor and gearhead in same direction
Insulation class		F

1) 1000 cycles per hour

2) Permissible 1000 times during the life span of the gearhead

3) At 20°C ambient temperature

4) Based on the flange center

5) At 20°C gearhead temperature

6) Limit motor values to maximum values of the gearhead



The maximum and nominal values of the gearhead can limit the output values in some circumstances.

$i = 21$

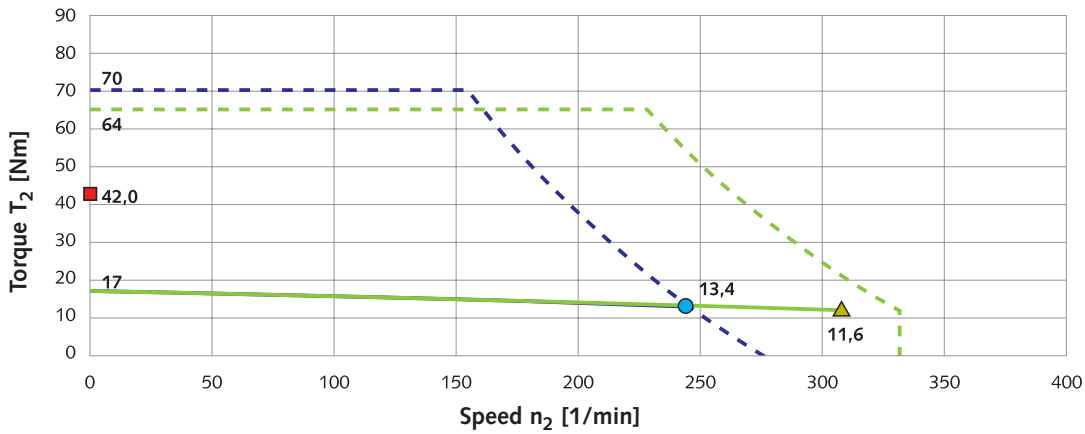

$i = 31$

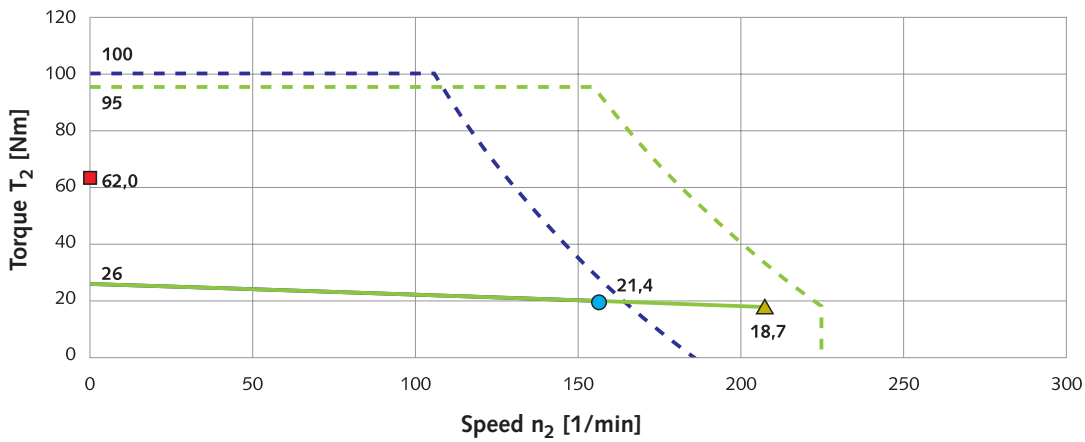

$i = 61$

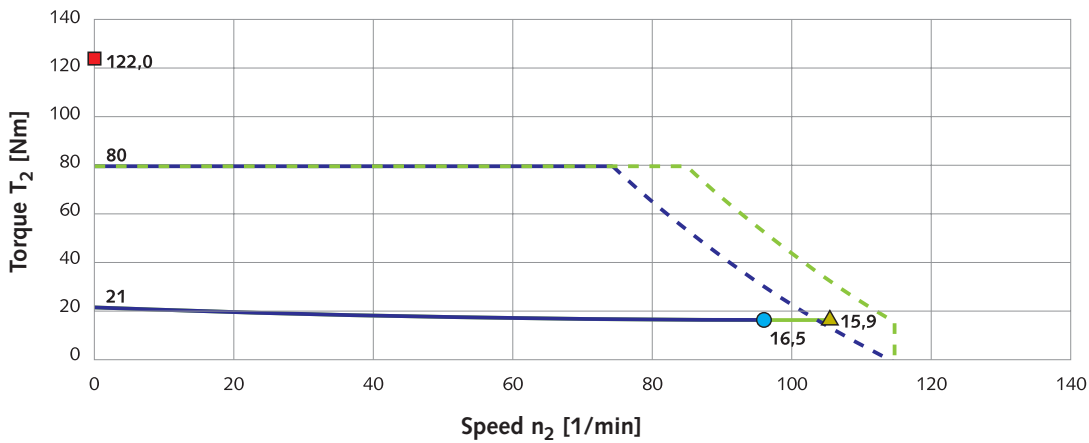

$i = 91$

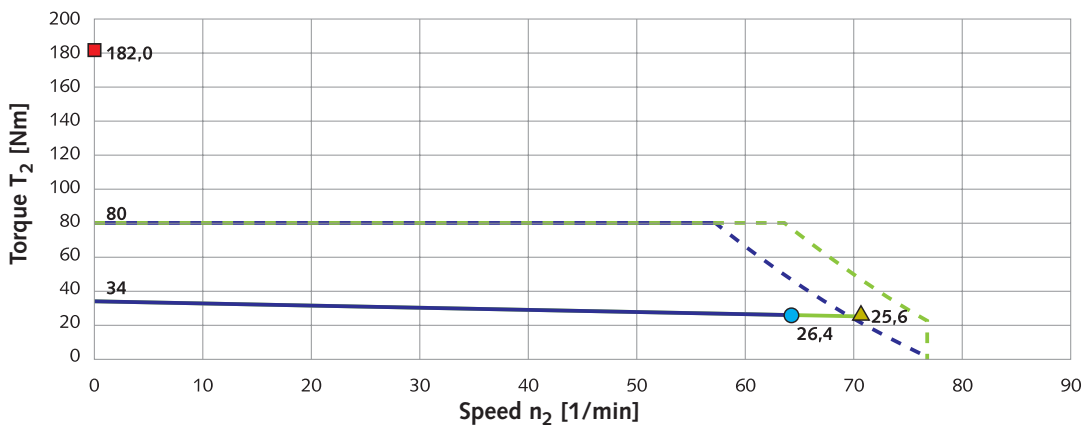

- Max. output torque 320V DC
- Nominal torque 320V DC
- Holding torque: brake
- Max. output torque 600V DC
- Nominal torque 600V DC
- Nominal point 320V DC
- ▲ Nominal point 600V DC

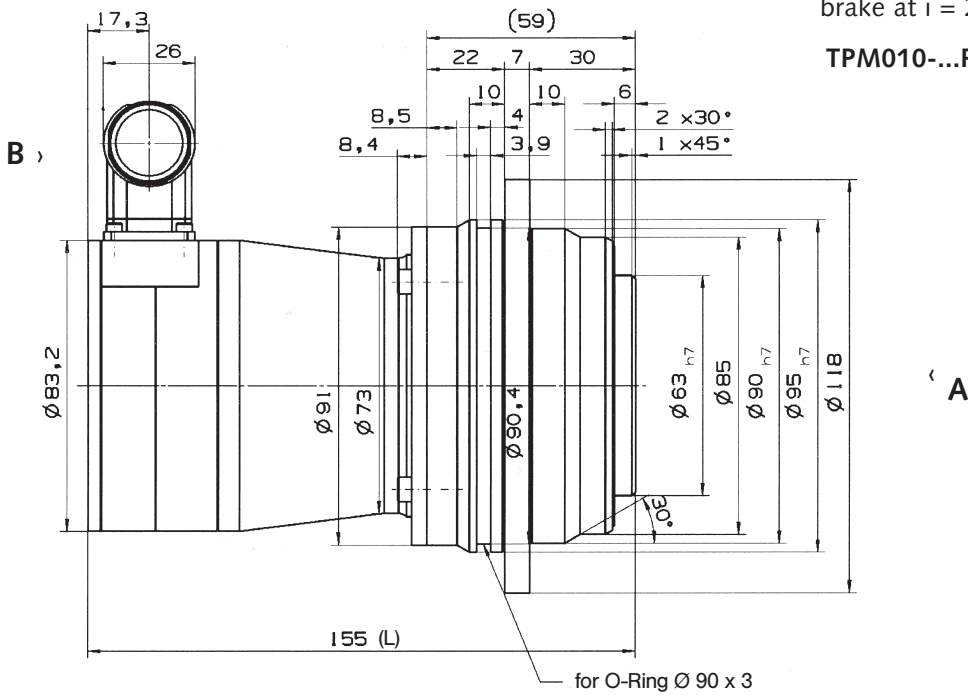

Standard version with resolver **without** brake at  $i = 21/31$

**TPM010-...R-...-OH.-030**

Total length L for other options		
TPM 010, $i = 21, 31$	Without brake	With brake
Heidenhain motor encoder	206.4	242.4
Stegmann motor encoder	184	219.5

View A

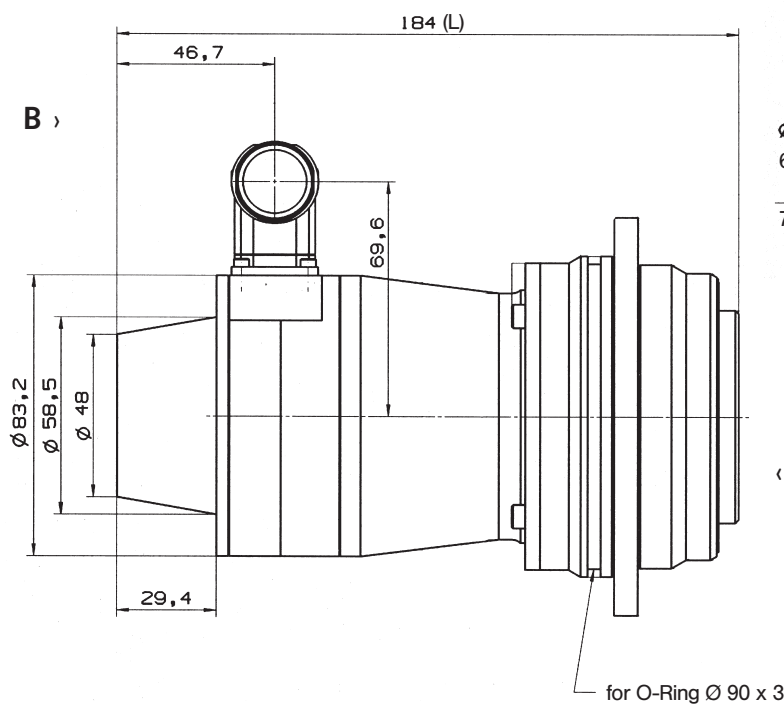
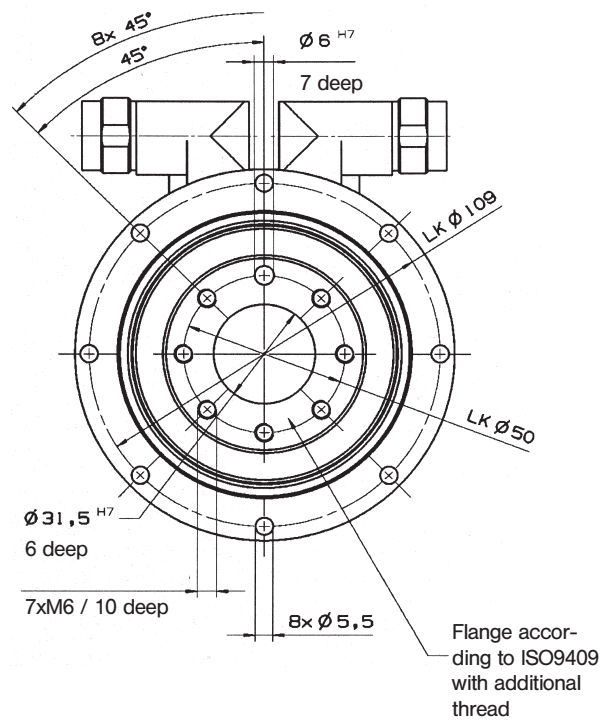

Standard version with resolver **with** brake at  $i = 21/31$

**TPM 010-...R-...-BP.-030**



Standard version with resolver **without**  
brake at i=61/91

TPM010-...R-....-OH.-015

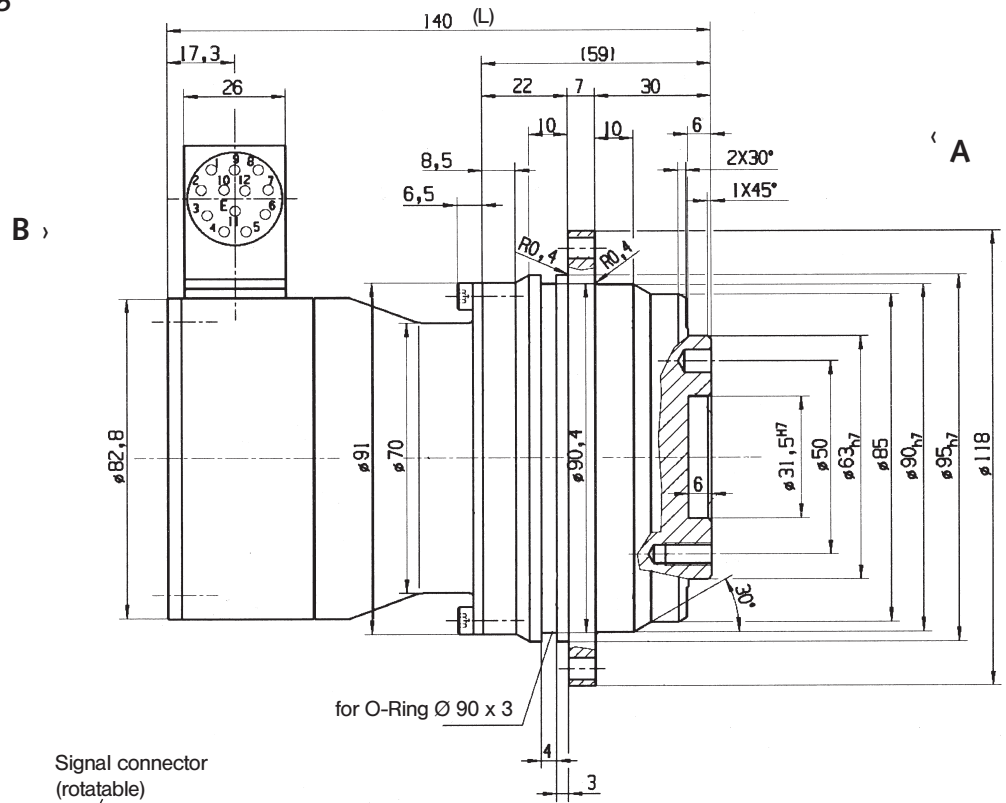

View B

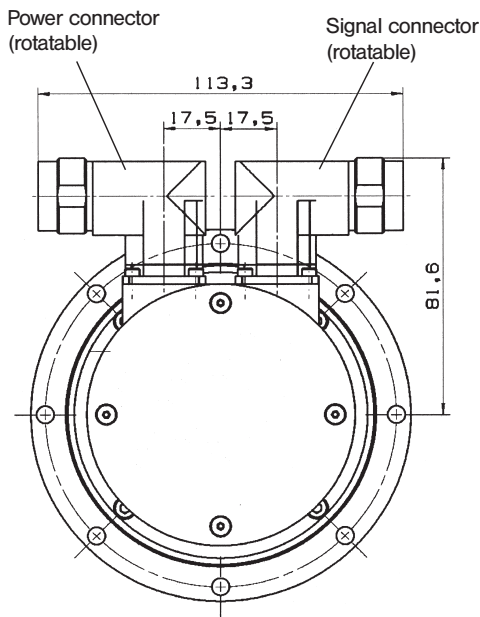

Total length L for other options

TPM 010, i = 61, 91	Without brake	With brake
Heidenhain motor encoder	191	229
Stegmann motor encoder	170	204.9

Standard version with resolver **with**  
brake at i=61/91

TPM 010-...R-....-BP.-015

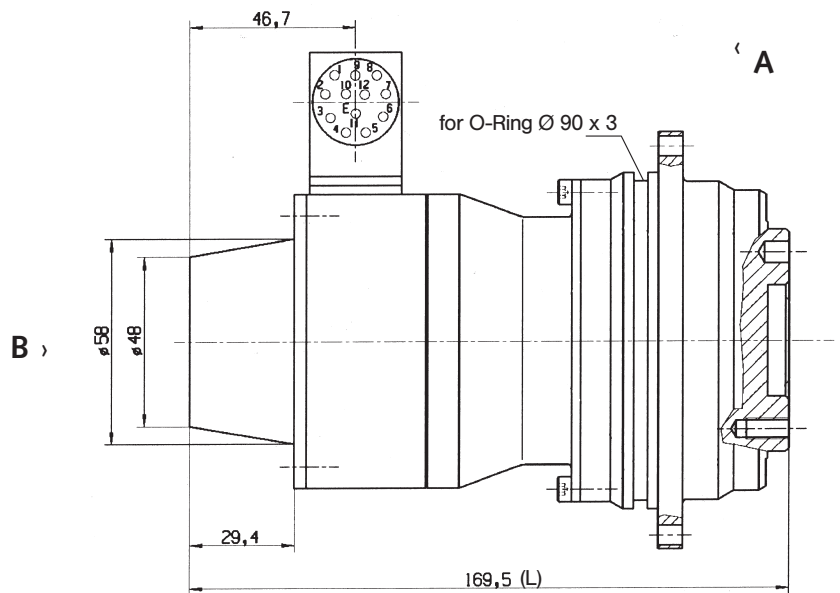

# TPM 025 - Technical data, characteristic curves and drawings

## Gearhead data

Ratio	i			21, 31, 61, 91
Max. acceleration torque <sup>1)</sup>	$T_{2B}$	Nm	i = 31	300
			i = 21, 61, 91	250
Emergency Stop torque <sup>2)</sup>	$T_{2Not}$	Nm		625
Nominal output torque	$T_{2N}$	Nm	i = 31	170
			i = 21, 61, 91	100
Max. input speed	$n_{1Max}$	min <sup>-1</sup>		6,000
Nominal input speed <sup>3)</sup>	$n_{1N}$	min <sup>-1</sup>		5,900
Torsional backlash	$j_t$	arcmin	Standard	≤ 3
			reduziert	≤ 1
Torsional rigidity	$C_{t21}$	Nm/arcmin		56
Max. axial force <sup>4)</sup>	$F_{2AMax}$	N		4,150
Max. tilting torque	$M_{2TiltMax}$	Nm		413
Tilting rigidity	$C_{2K}$	Nm/arcmin		550
No-load running torque ( $n_1 = 3000 \text{ min}^{-1}$ )	$T_{012}$	Nm	i = 31	0.6
			i = 91	0.3
Moment of inertia reflected to the input	$J_{Gear}$	kgcm <sup>2</sup>	i = 21	0.10
			i = 31	0.06
			i = 61	0.01
			i = 91	0.01

## Motor data

			i = 21, 31		i = 61, 91	
DC bus voltage	$U_D$	VDC	320	600	320	600
Peak torque <sup>6)</sup>	$M_{max}$	Nm	11.70	12.40	4.20	4.20
Continuous stall torque	$M_0$	Nm	5.00	5.00	1.70	1.70
Nominal torque	$M_N$	Nm	3.30	3.40	1.40	1.30
Peak current <sup>6)</sup>	$I_{Max}$	A	25.00	10.60	10.80	7.00
Nominal current	$I_N$	A	6.00	3.40	3.10	1.80
No-load speed <sup>6)</sup>	$n_0$	min <sup>-1</sup>	6,380	6,000	7,300	7,800
Nominal speed <sup>6)</sup>	$n_N$	min <sup>-1</sup>	5,200	4,838	5,625	6,200
Max. power	$P_{Max}$	kW	4.04	4.22	1.72	1.85
Moment of inertia with resolver	$J_{Mot.}$	kgcm <sup>2</sup>	2.39		0.86	

## General data

Protection class		IP64
Permissible transmission temperature	°C	-10 to +90
Mounting position		Any
Lubrication		Synthetic oil, ISO VG 220
Paint		RAL 5002 (Blue)
Noise level ( $n_1 = 3000 \text{ min}^{-1}$ )	dB(A)	≤ 65
Weight without/with brake	kg	9.0/9.8 at i = 21/31   7.6/8.4 at i = 61/91
Direction of rotation		motor and gearhead in same direction
Insulation class		F

1) 1000 cycles per hour

2) Permissible 1000 times during the life span of the gearhead

3) At 20°C ambient temperature

4) Based on the flange center

5) At 20°C gearhead temperature

6) Limit motor values to maximum values of the gearhead



The maximum and nominal values of the gearhead can limit the output values in some circumstances.

$i = 21$

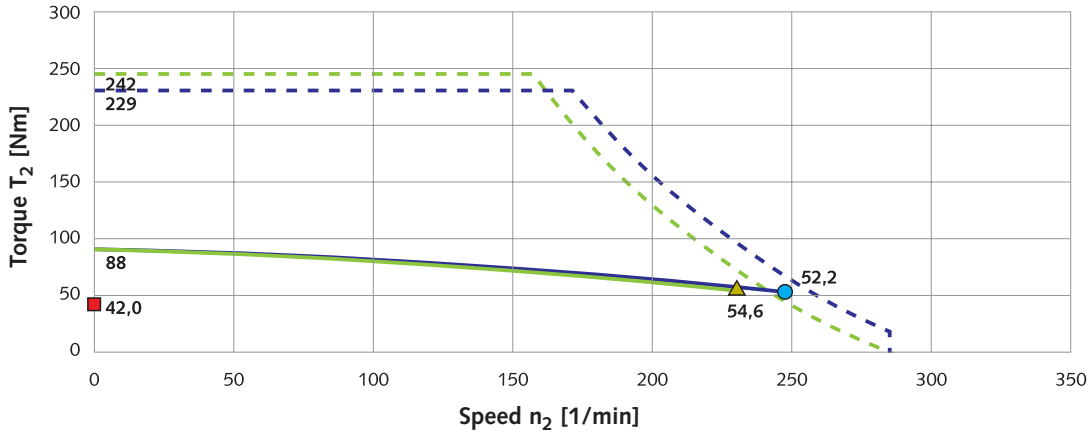

$i = 31$

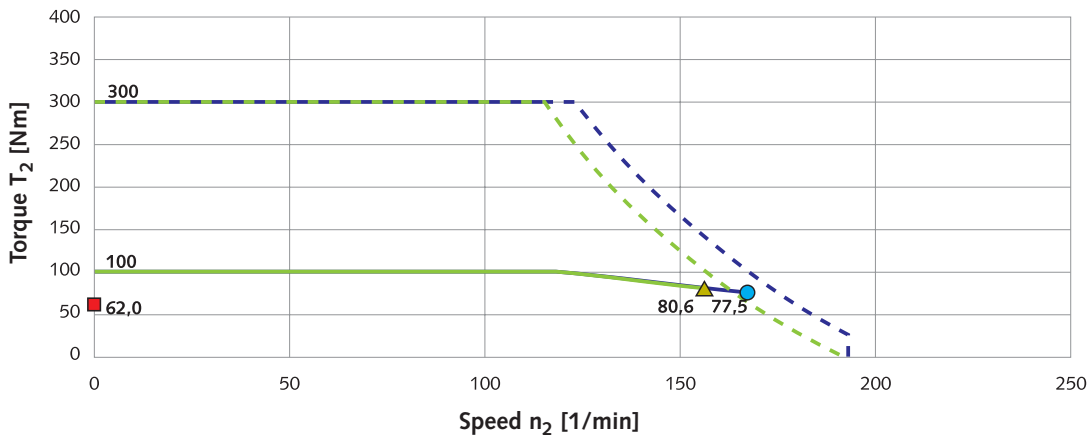

$i = 61$

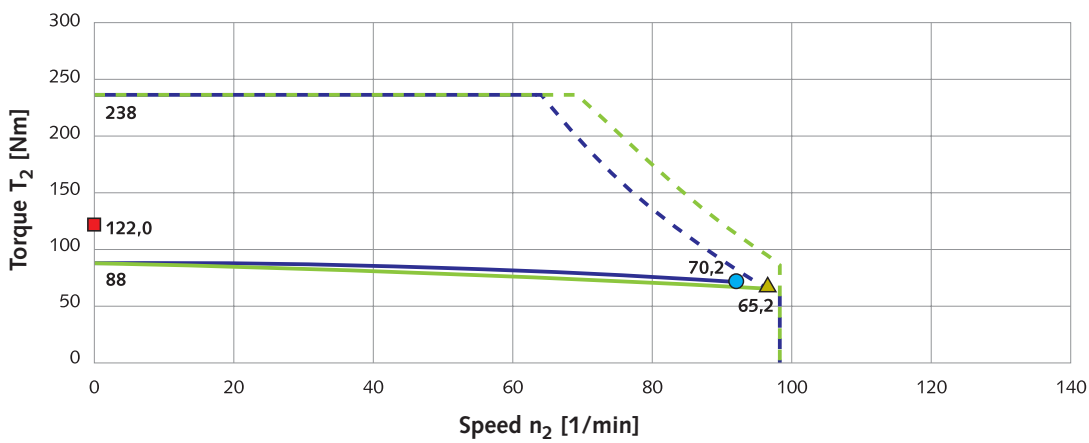

$i = 91$

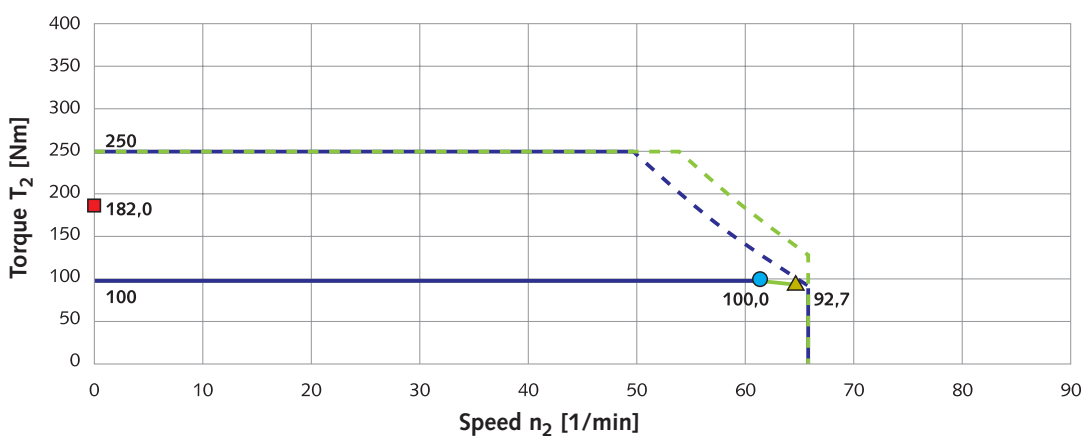

- - - Max. output torque 320V DC
- Nominal torque 320V DC
- Holding torque: brake
- - - Max. output torque 600V DC
- Nominal torque 600V DC
- Nominal point 320V DC
- ▲ Nominal point 600V DC

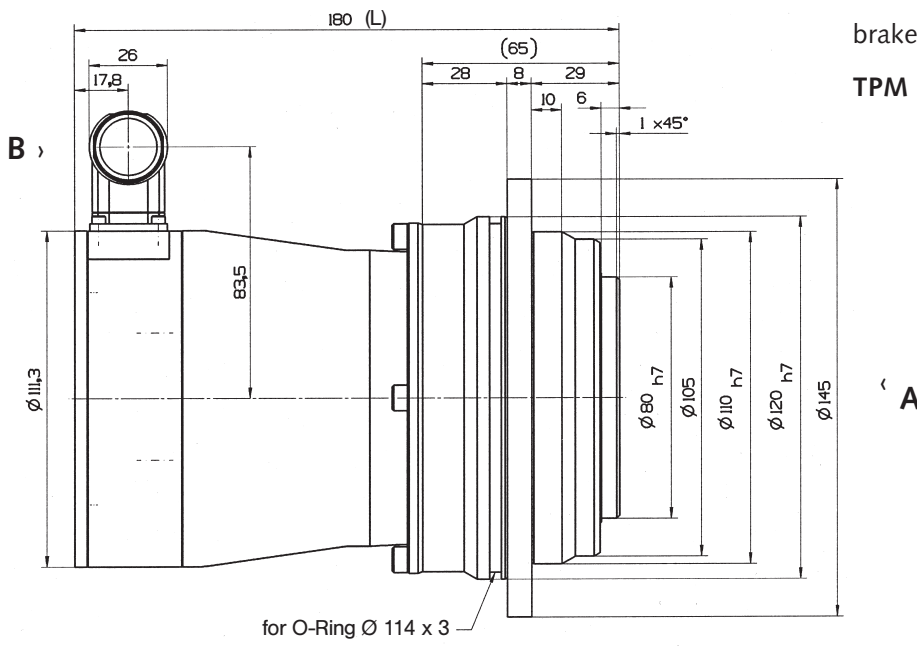

Standard version with resolver **without** brake at  $i = 21/31$

**TPM 025-...R-....-OH.-045**

View A

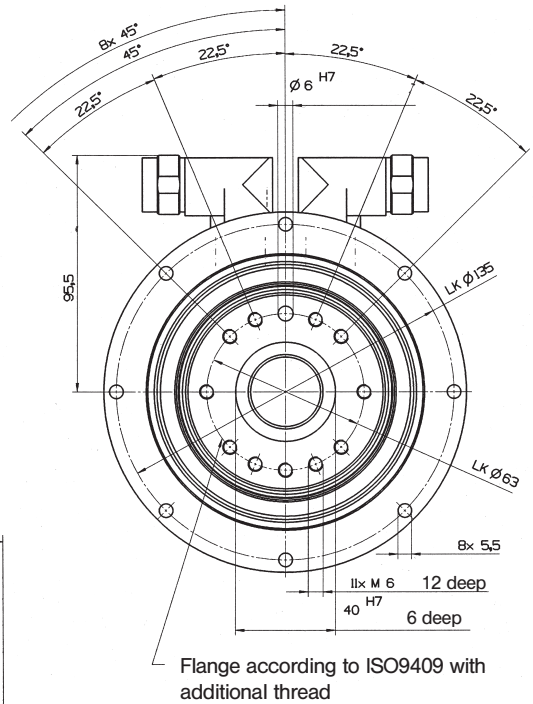

Total length L for other options		
TPM 025, $i = 21, 31$	Without brake	With brake
Heidenhain motor encoder	227	268
Stegmann motor encoder	222.5	251

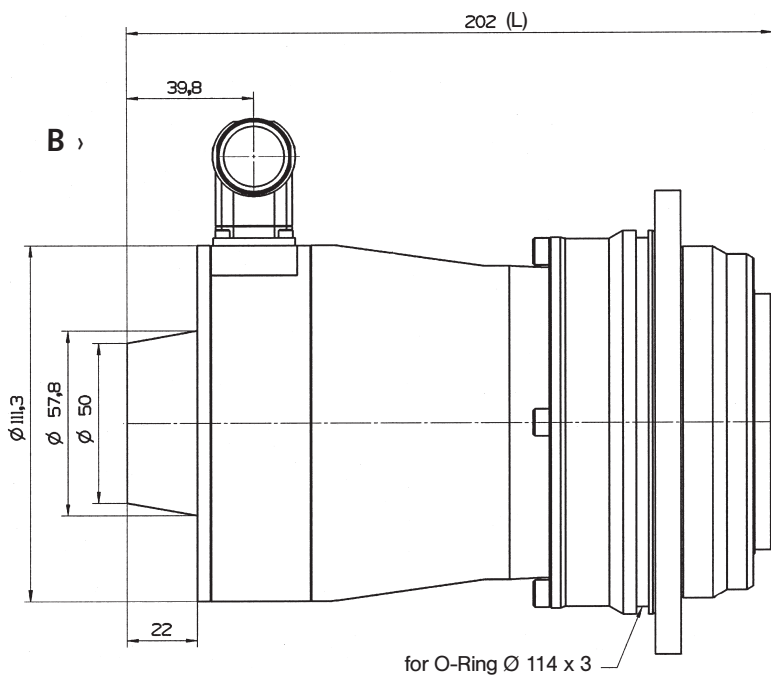

Standard version with resolver **with** brake at  $i = 21/31$

**TPM 025-...R-....-BP.-045**

Standard version with resolver **without**  
brake at i=61/91

TPM 025-...R-....-OH.-015

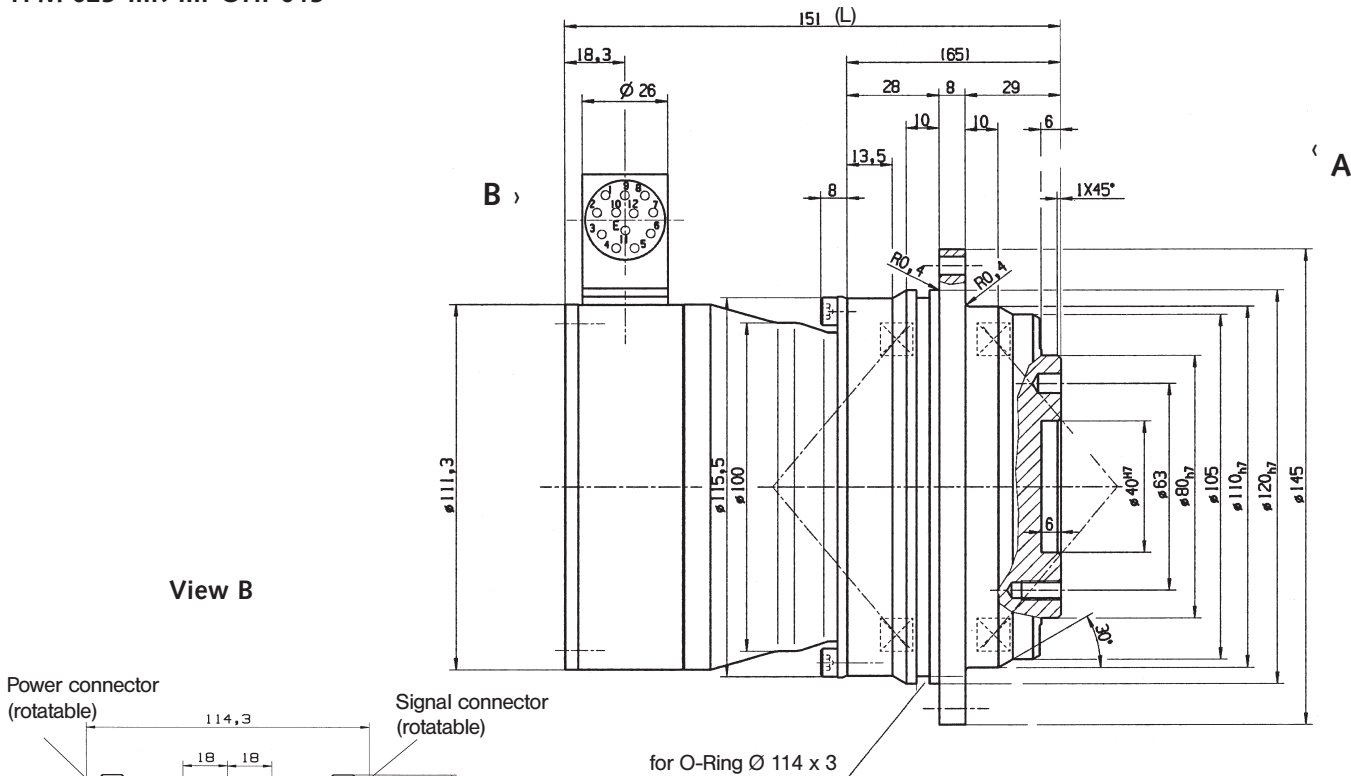

Total length L for other options		
TPM 025, i = 61, 91	Without brake	With brake
Heidenhain motor encoder	196	237.5
Stegmann motor encoder	192	221

Standard version with resolver **with**  
brake at i=61/91

TPM 025-...R-....-BP.-015

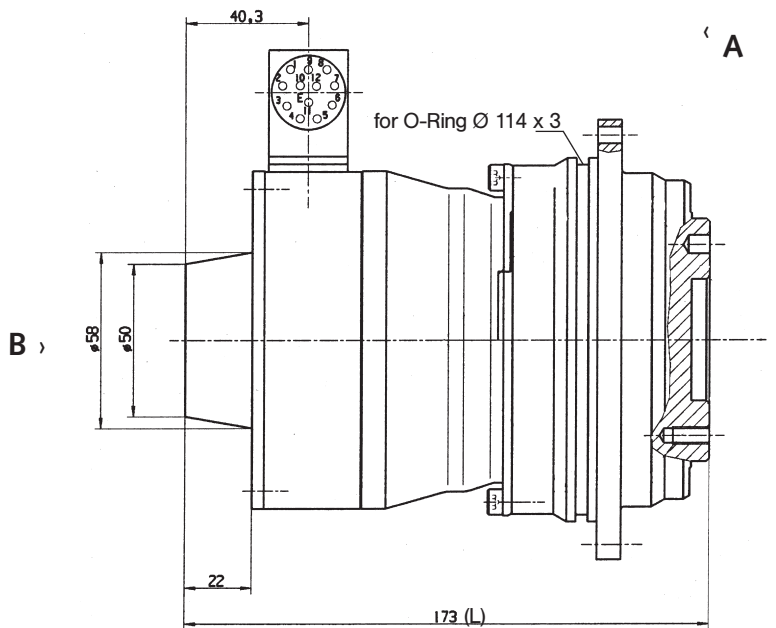

# TPM 050 - Technical data, characteristic curves and drawings

## Gearhead data

Ratio	i			21, 31, 61, 91
Max. acceleration torque <sup>1)</sup>	$T_{2B}$	Nm	i = 31 i = 21, 61, 91	650 500
Emergency Stop torque <sup>2)</sup>	$T_{2Not}$	Nm		1,250
Nominal output torque	$T_{2N}$	Nm	i = 31 i = 21, 61, 91	370 220
Max. input speed	$n_{1Max}$	min <sup>-1</sup>		5,000
Nominal input speed <sup>3)</sup>	$n_{1N}$	min <sup>-1</sup>		4,650
Torsional backlash	$j_t$	arcmin	Standard Reduced	≤ 3 ≤ 1
Torsional rigidity	$C_{t21}$	Nm/arcmin		118
Max. axial force <sup>4)</sup>	$F_{2AMax}$	N		6,130
Max. tilting torque	$M_{2TiltMax}$	Nm		1,295
Tilting rigidity	$C_{2K}$	Nm/arcmin		560
No-load running torque ( $n_1 = 3000 \text{ min}^{-1}$ ) <sup>5)</sup>	$T_{012}$	Nm	i = 31 i = 91	1.3 1.1
Moment of inertia reflected to the input	$J_{Gear}$	kgcm <sup>2</sup>	i = 21 i = 31 i = 61 i = 91	0.37 0.26 0.06 0.05

## Motor data

			i = 21, 31		i = 61, 91	
DC bus voltage	$U_D$	VDC	320	600	320	600
Peak torque <sup>6)</sup>	$M_{Max}$	Nm	30.50	32.50	7.80	7.80
Continuous stall torque	$M_0$	Nm	13.60	13.60	3.60	3.50
Nominal torque	$M_N$	Nm	6.60	4.90	2.80	2.50
Peak current <sup>6)</sup>	$I_{Max}$	A	75.00	54.00	19.60	13.70
Nominal current	$I_N$	A	12.40	5.60	4.20	2.60
No-load speed <sup>6)</sup>	$n_0$	min <sup>-1</sup>	6,380	7,180	5,000	5,900
Nominal speed <sup>6)</sup>	$n_N$	min <sup>-1</sup>	5,375	6,000	3,775	4,562
Max. power	$P_{Max}$	kW	11.18	13.0	2.25	2.53
Moment of inertia with resolver	$J_{Mot.}$	kgcm <sup>2</sup>	9.09		2.28	

## General data

Protection class		IP64
Operating temperature range	°C	-10 to +90
Mounting position		Any
Lubrication		Synthetic oil, ISO VG 220
Paint		RAL 5002 (Blau)
Noise level ( $n_1 = 3000 \text{ min}^{-1}$ )	dB(A)	≤ 65
Weight without/with brake	kg	21.3/23.7 at i = 21/31   15.1/16.2 at i = 61/91
Direction of rotation		motor and gearhead in same direction
Insulation class		F

1) 1000 cycles per hour

2) Permissible 1000 times during the life span of the gearhead

3) At 20°C ambient temperature

4) Based on the flange center

5) At 20°C gearhead temperature

6) Limit motor values to maximum values of the gearhead



The maximum and nominal values of the gearhead can limit the output values in some circumstances.

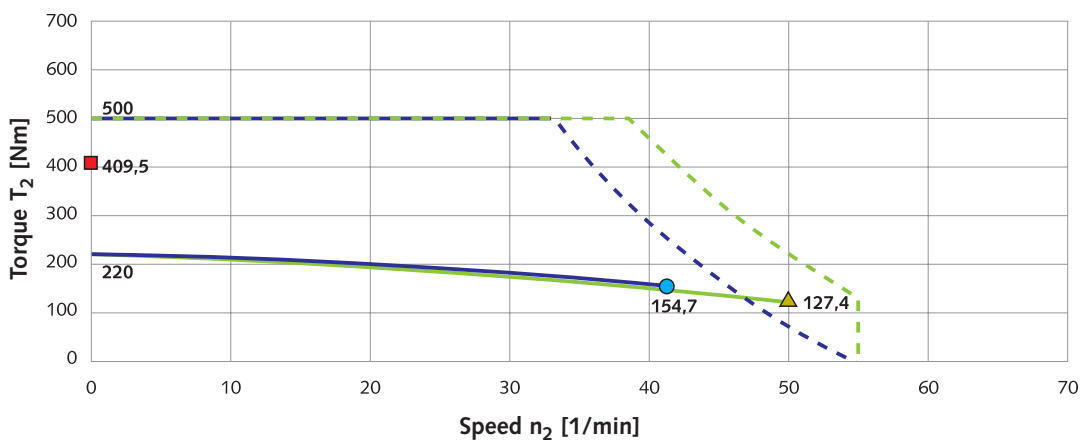
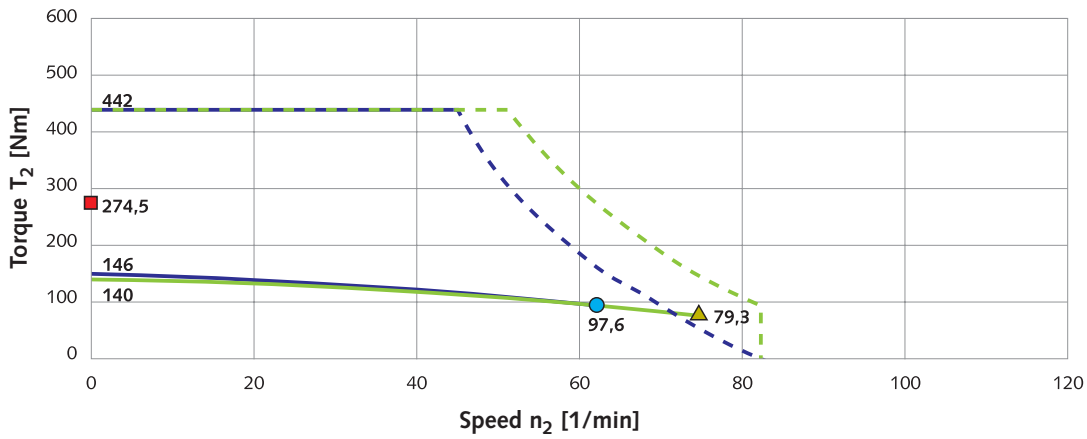
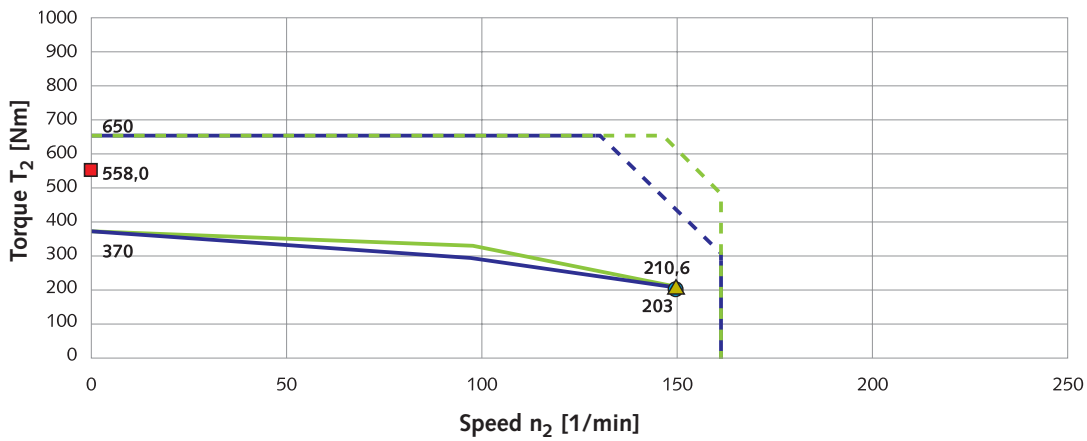
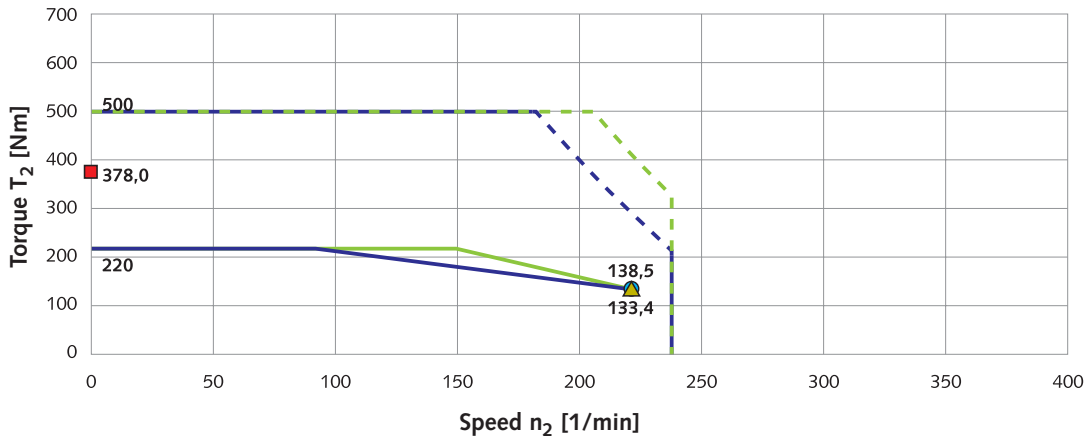

- Max. output torque 320V DC
- Max. output torque 600V DC
- Nominal torque 320V DC
- Nominal torque 600V DC
- Holding torque: brake
- Nominal point 320V DC
- ▲ Nominal point 600V DC

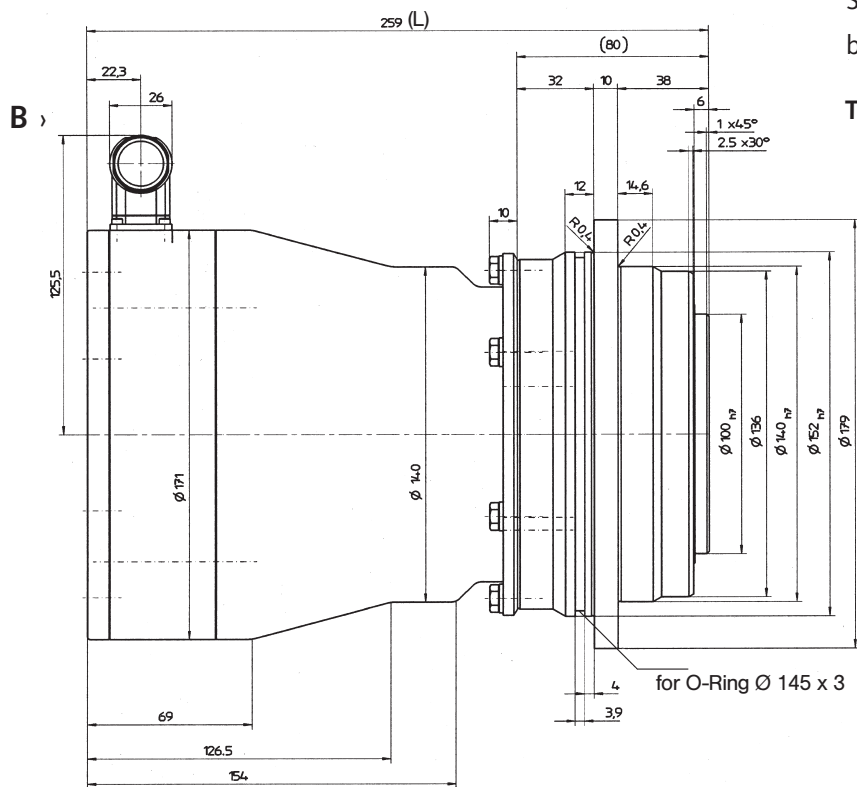

Standard version with resolver **without** brake at  $i = 21/31$

**TPM 050-...R-...-OH.-060**

**View A**

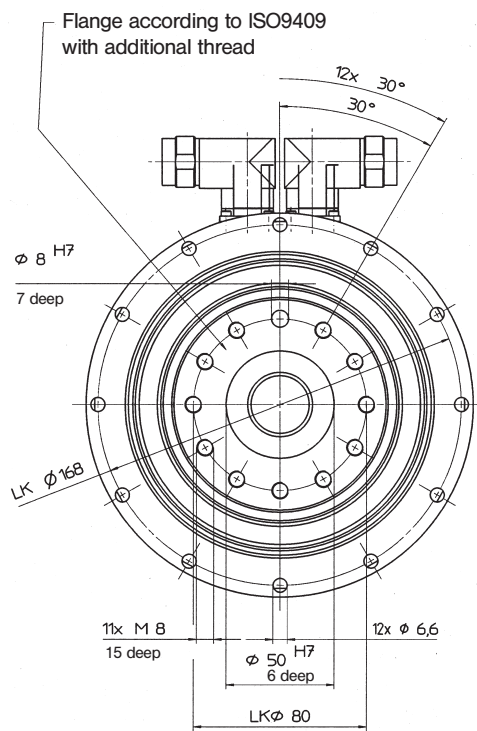

Total length L for other options		
TPM 050, $i = 21, 31$	Without brake	With brake
Heidenhain motor encoder	300	364
Stegmann motor encoder	274	346

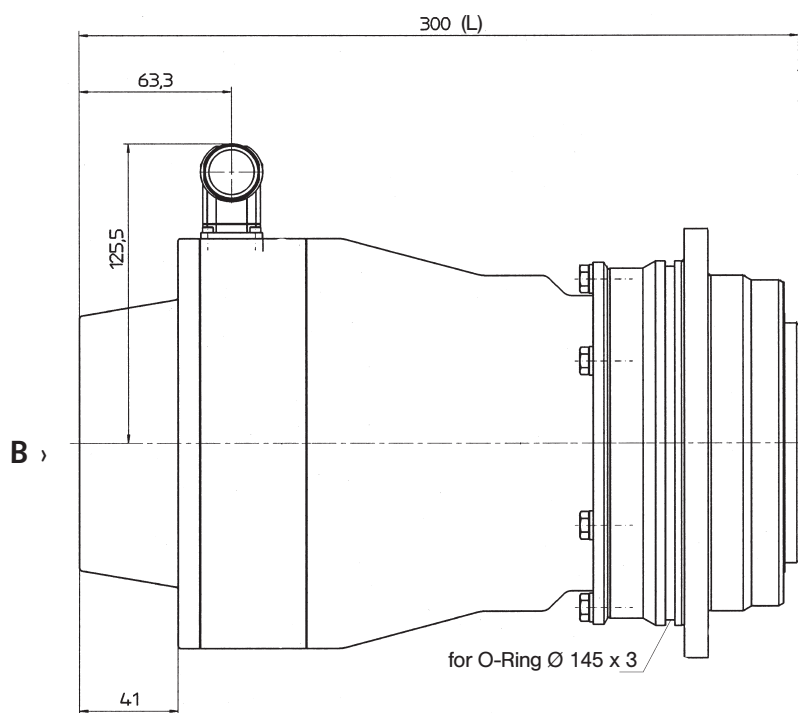

Standard version with resolver **with** brake at  $i = 21/31$

**TPM 050-...R-...-BP.-060**



Standard version with resolver **without**  
brake at i=61/91

TPM 050-...R-....-OH.-015

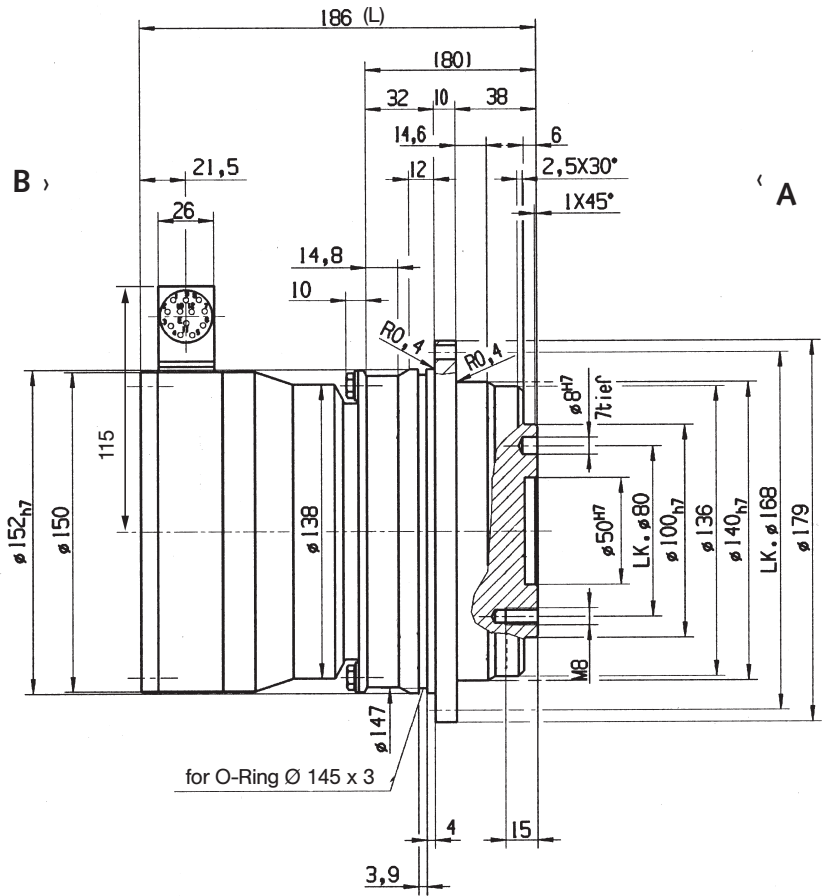

View B

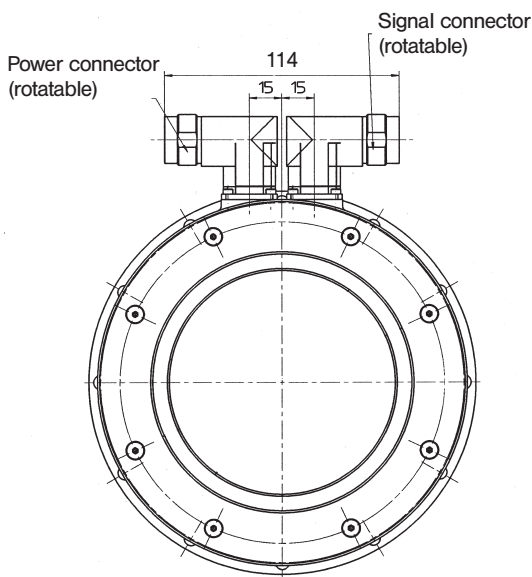

Total length L for other options

TPM 050, i = 61, 91	Without brake	With brake
Heidenhain motor encoder	226.5	273.5
Stegmann motor encoder	226.6	256.5

Standard version with resolver **with**  
brake at i=61/91

TPM 050-...R-....-BP.-015

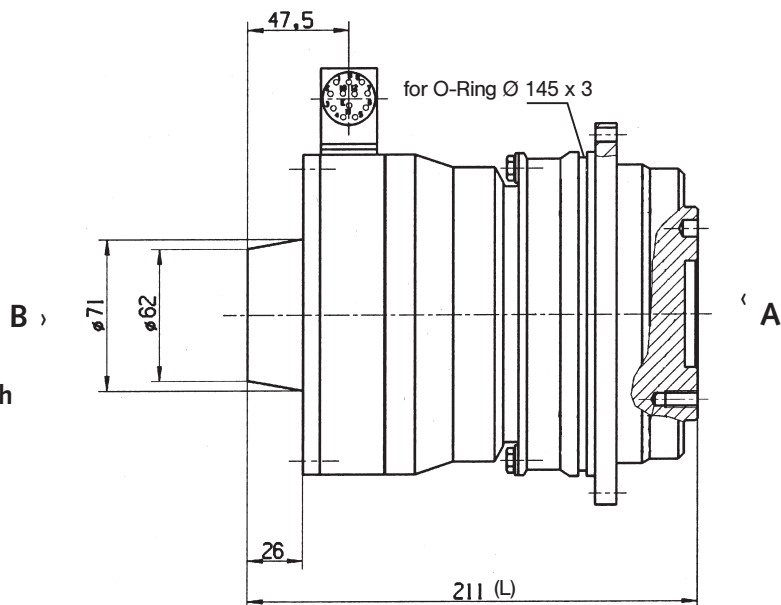



# TPM 110 - Technical data, characteristic curves and drawings

## Gearhead data

Ratio	i			21, 31, 61, 91
Max. acceleration torque <sup>1)</sup>	$T_{2B}$	Nm	i = 31 i = 21 / i = 61, 91	1,600 1,100 / 1,300
Emergency Stop torque <sup>2)</sup>	$T_{2Not}$	Nm		2,750
Nominal output torque	$T_{2N}$	Nm	i = 31 i = 61, 91 i = 21	1,230 700 640
Max. input speed	$n_{1Max}$	min <sup>-1</sup>		4,500
Nominal input speed <sup>3)</sup>	$n_{1N}$	min <sup>-1</sup>		3,500
Torsional backlash	$j_t$	arcmin	Standard Reduced	≤ 3 ≤ 1
Torsional rigidity	$C_{t21}$	Nm/arcmin		300
Max. axial force <sup>4)</sup>	$F_{2AMax}$	N		10,050
Max. tilting torque	$M_{2TiltMax}$	Nm		3,064
Tilting rigidity	$C_{2K}$	Nm/arcmin		1,452
No-load running torque ( $n_1 = 3000 \text{ min}^{-1}$ ) <sup>5)</sup>	$T_{012}$	Nm	i = 31 i = 91	2.8 2.0
Moment of inertia reflected to the input	$J_{Gear}$	kgcm <sup>2</sup>	i = 21 i = 31 i = 61 i = 91	1.72 1.16 0.27 0.20

## Motor data

			i = 21, 31		i = 61, 91	
DC bus voltage	$U_D$	VDC	320	600	320	600
Peak torque <sup>6)</sup>	$M_{Max}$	Nm	39.60	39.70	30.50	32.60
Continuous stall torque	$M_0$	Nm	17.70	17.80	13.60	13.60
Nominal torque	$M_N$	Nm	12.80	13.80	6.60	4.90
Peak current <sup>6)</sup>	$I_{Max}$	A	58.00	26.20	75.00	54.00
Nominal current	$I_N$	A	13.50	9.70	12.40	5.60
No-load speed <sup>6)</sup>	$n_0$	min <sup>-1</sup>	3,700	4,326	6,380	7,180
Nominal speed <sup>6)</sup>	$n_N$	min <sup>-1</sup>	2,875	3,300	5,375	6,000
Max. power	$P_{Max}$	kW	8.30	11.30	11.18	13.00
Moment of inertia with resolver	$J_{Mot.}$	kgcm <sup>2</sup>	11.95		9.68	

## General data

Protection class		IP64
Operating temperature range	°C	-10 to +90
Mounting position		Any
Lubrication		Synthetic oil, ISO VG 220
Paint		RAL 5002 (Blue)
Noise level ( $n_1 = 3000 \text{ min}^{-1}$ )	dB(A)	≤ 65
Weight without/with brake	kg	37.1/39.6 at i = 21/31   35.9/38.3 at i = 61/91
Direction of rotation		motor and gearhead in same direction
Insulation class		F

1) 1000 cycles per hour

2) Permissible 1000 times during the life span of the gearhead

3) At 20°C ambient temperature

4) Based on the flange center

5) At 20°C gearhead temperature

6) Limit motor values to maximum values of the gearhead



The maximum and nominal values of the gearhead can limit the output values in some circumstances.

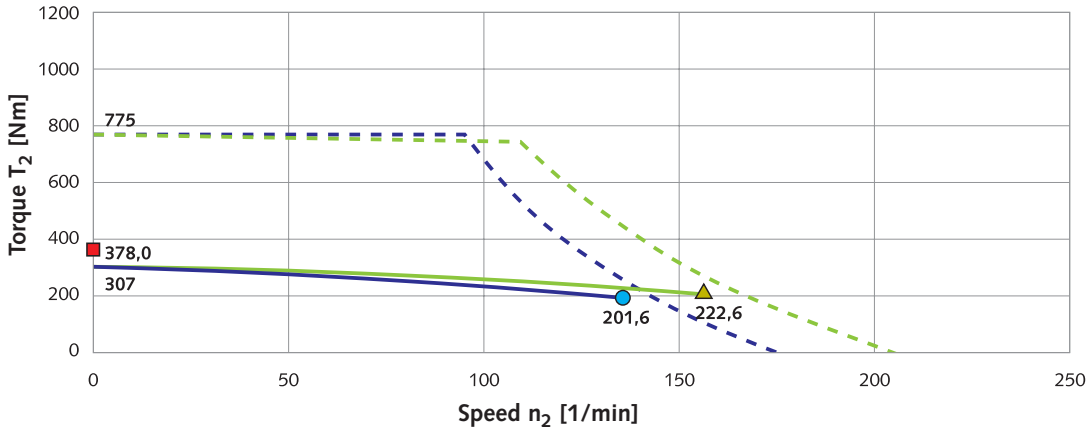

**i = 21**

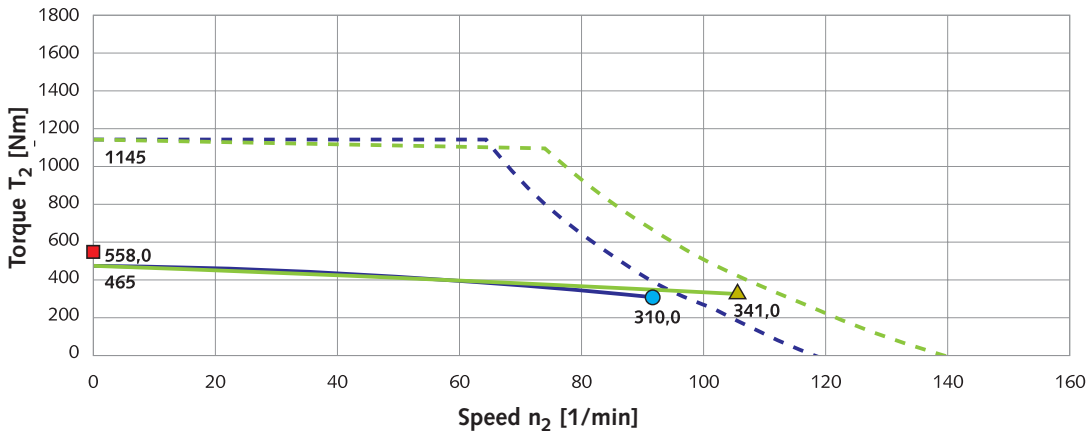

**i = 31**

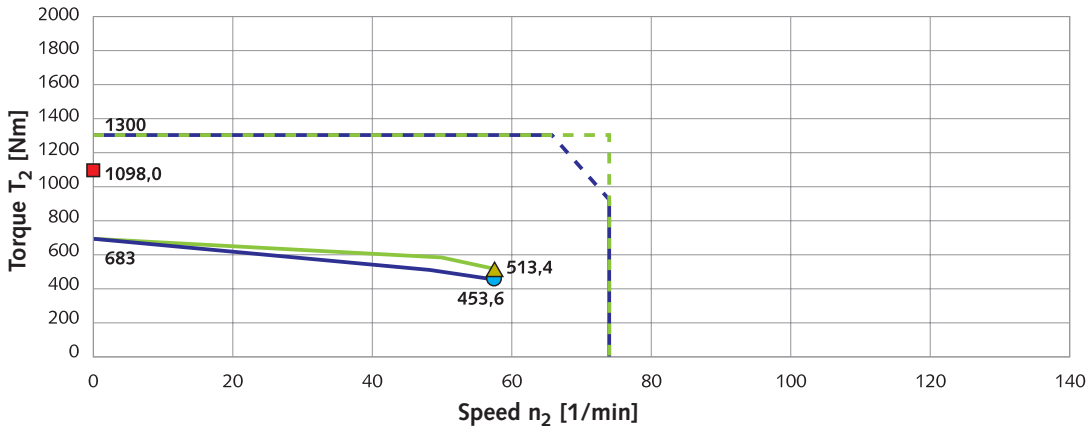

**i = 61**

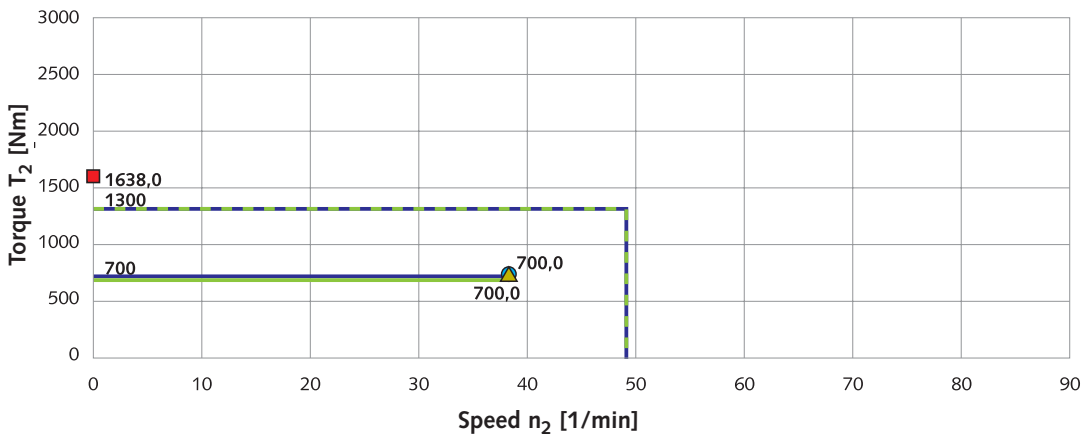

**i = 91**

- Max. output torque 320V DC
- Max. output torque 600V DC
- Nominal torque 320V DC
- Nominal torque 600V DC
- Holding torque: brake
- Nominal point 320V DC
- ▲ Nominal point 600V DC

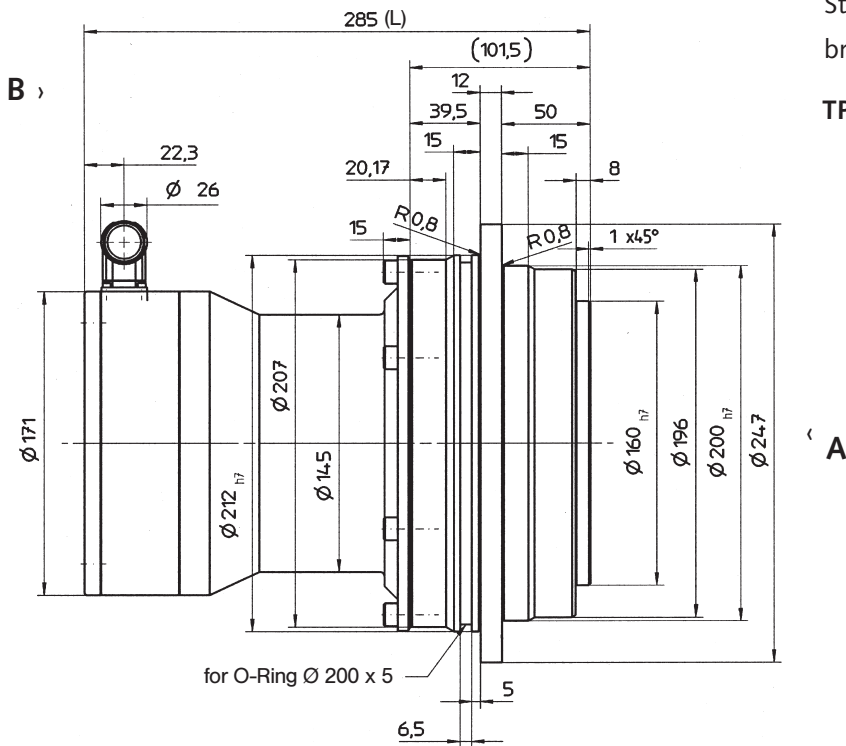

Standard version with resolver **without** brake at  $i = 21/31$

TPM 110-...R-...-OH.-075

View A

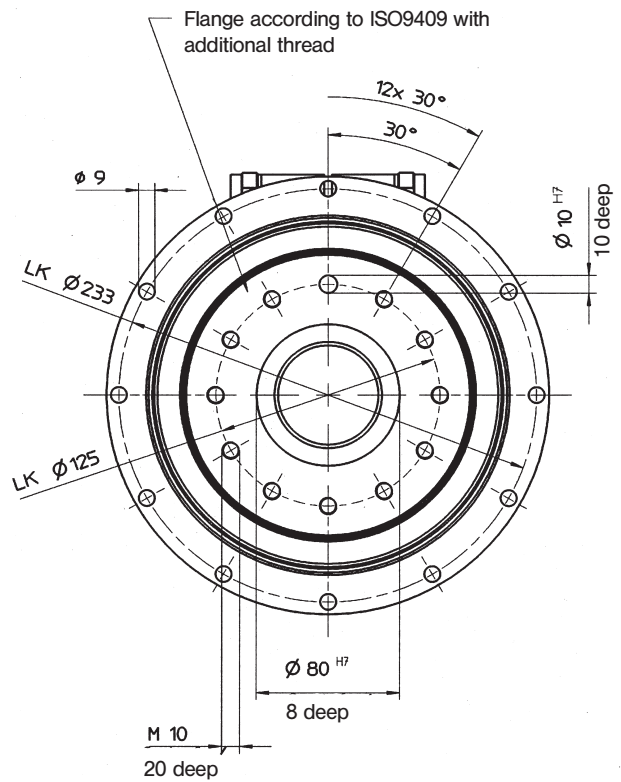

Total length L for other options		
TPM 110, $i = 21, 31$	Without brake	With brake
Heidenhain motor encoder	326	390
Stegmann motor encoder	300	372

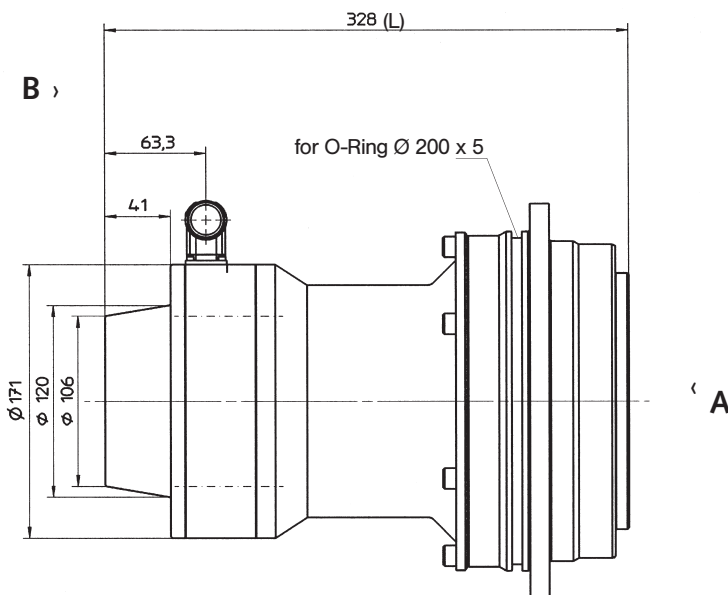

Standard version with resolver **with** brake at  $i = 21/31$

TPM 110-...R-...-BP.-075

Standard version with resolver **without**  
brake at i=61/91

TPM 110-...R-...-OH.-060

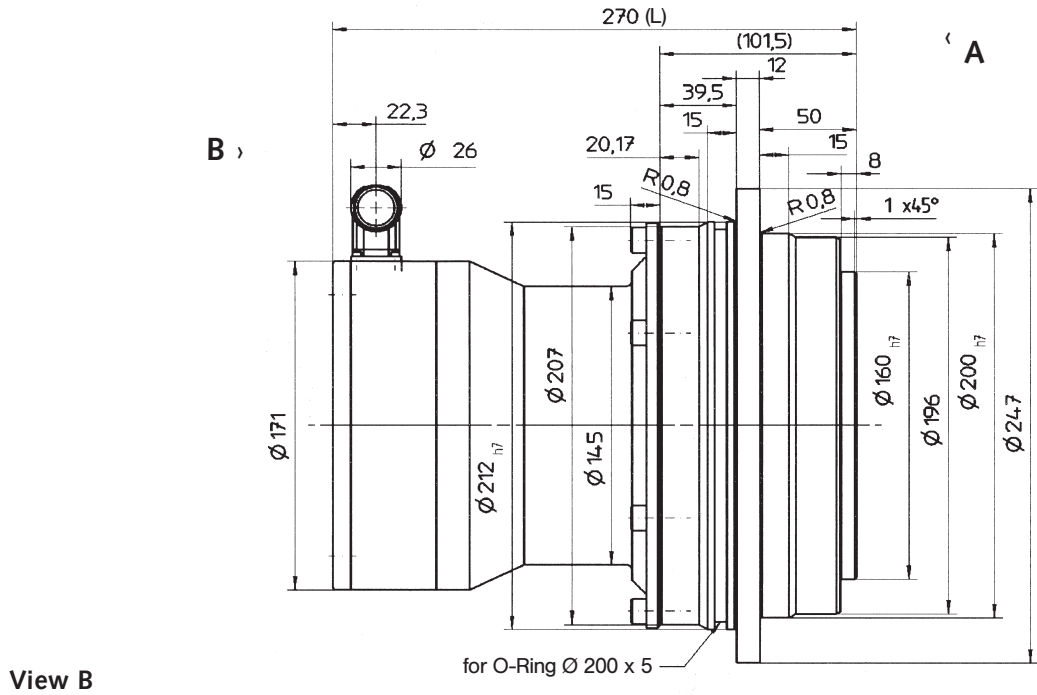

View B

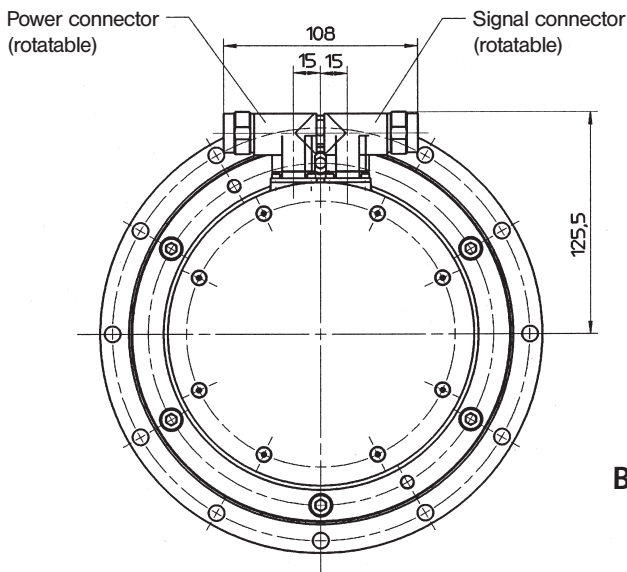

Total length L for other options		
TPM 110, i = 61, 91	Without brake	With brake
Heidenhain motor encoder	311	375
Stegmann motor encoder	285	357

Standard version with resolver **with**  
brake at i=61/91

TPM 110-...R-...-BP.-060

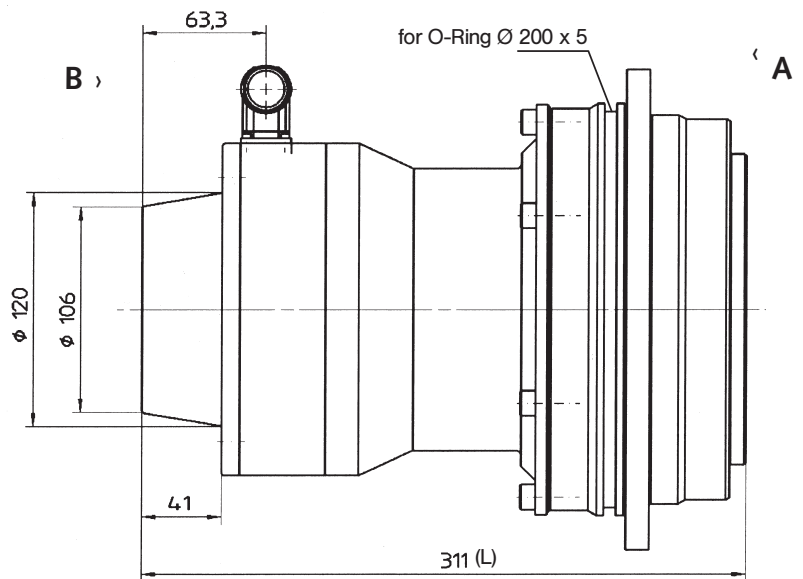

# TPMA 025 - Technical data, characteristic curves and drawings

## Gearhead data

Ratio	i			110, 220
Max. acceleration torque <sup>1)</sup>	$T_{2B}$	Nm		480
Emergency Stop torque <sup>2)</sup>	$T_{2Not}$	Nm		1,200
Nominal output torque	$T_{2N}$	Nm		260
Max. input speed	$n_{1Max}$	min <sup>-1</sup>		6,000
Nominal input speed <sup>3)</sup>	$n_{1N}$	min <sup>-1</sup>		3,200
Torsional backlash	$j_t$	arcmin		≤ 1
Torsional rigidity	$C_{t21}$	Nm/arcmin		97
Max. axial force <sup>4)</sup>	$F_{2AMax}$	N		4,150
Max. tilting torque	$M_{2TiltMax}$	Nm		413
Tilting rigidity	$C_{2K}$	Nm/arcmin		550
No-load running torque ( $n_1 = 3000 \text{ min}^{-1}$ ) <sup>5)</sup>	$T_{012}$	Nm		0.4
Moment of inertia reflected to the input	$J_{Gear}$	kgcm <sup>2</sup>	i = 110 i = 220	0.036 0.009

## Motor data

			i = 110, 220	
DC bus voltage	$U_D$	VDC	320	600
Peak torque <sup>6)</sup>	$M_{Max}$	Nm	4.20	4.20
Continuous stall torque	$M_0$	Nm	1.70	1.70
Nominal torque	$M_N$	Nm	1.40	1.30
Peak current <sup>6)</sup>	$I_{Max}$	A	10.80	7.00
Nominal current	$I_N$	A	3.10	1.80
No-load speed <sup>6)</sup>	$n_0$	min <sup>-1</sup>	7,300	7,800
Nominal speed <sup>6)</sup>	$n_N$	min <sup>-1</sup>	5,625	6,200
Max. power	$P_{Max}$	kW	1.72	1.85
Moment of inertia with resolver	$J_{Mot.}$	kgcm <sup>2</sup>	0.86	

## General data

Protection class		IP64
Operating temperature range	°C	-10 to +90
Mounting position		Any
Lubrication		Synthetic oil, ISO VG 220
Paint		RAL 5002 (Blue)
Noise level ( $n_1 = 3000 \text{ min}^{-1}$ )	dB(A)	≤ 65
Weight without/with brake	kg	8.4/9.3
Direction of rotation		motor and gearhead in same direction
Insulation class		F

1) 1000 cycles per hour

2) Permissible 1000 times during the life span of the gearhead

3) At 20°C ambient temperature

4) Based on the flange center

5) At 20°C gearhead temperature

6) Limit motor values to maximum values of the gearhead

The maximum and nominal values of the gearhead can limit the output values in some circumstances.

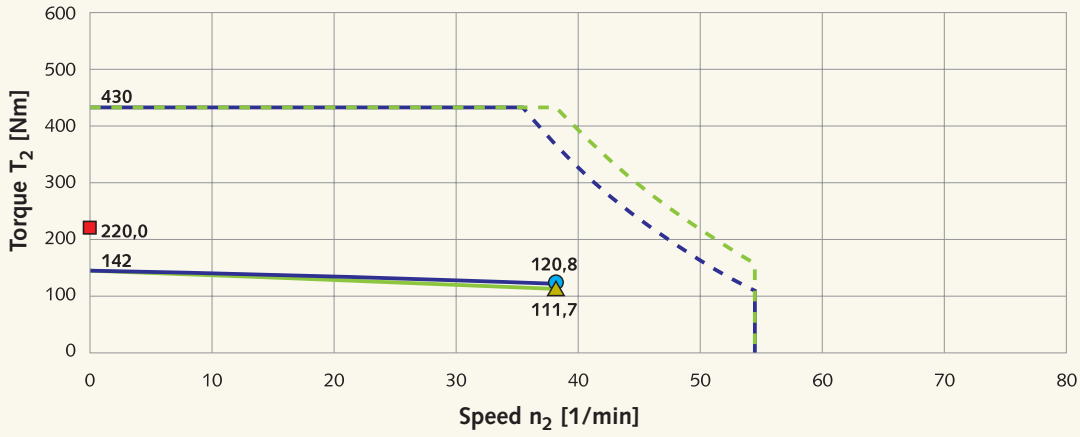

$i = 110$

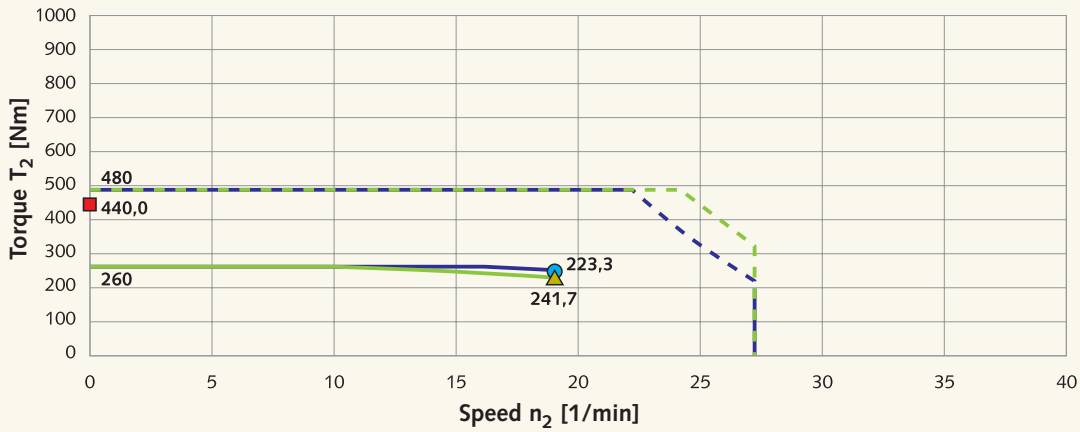

$i = 220$

- Max. output torque 320V DC
- Max. output torque 600V DC
- Nominal torque 320V DC
- Nominal torque 600V DC
- Holding torque: brake
- Nominal point 320V DC
- ▲ Nominal point 600V DC



Standard version with resolver **without**  
brake at i=110/220

**TPMA 025-...R-.....-OH.-015**

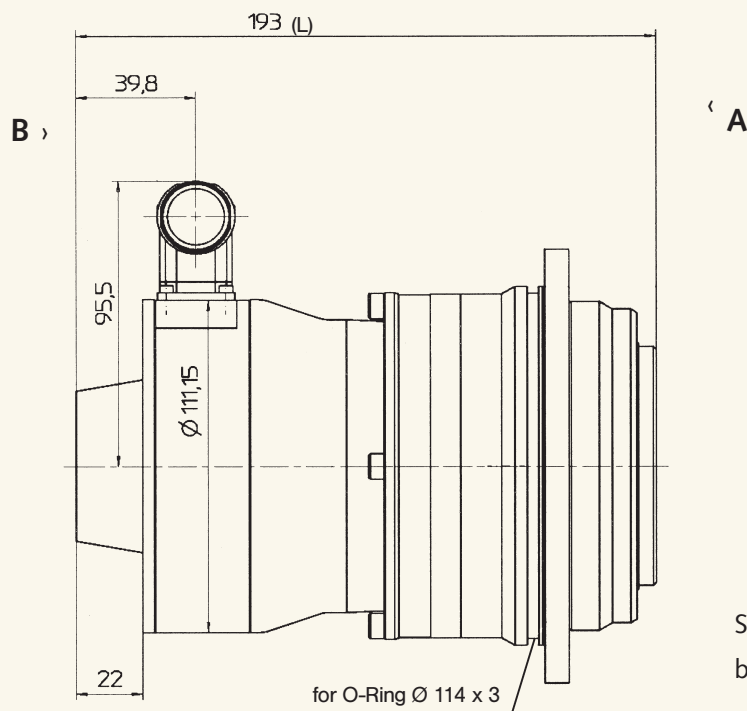
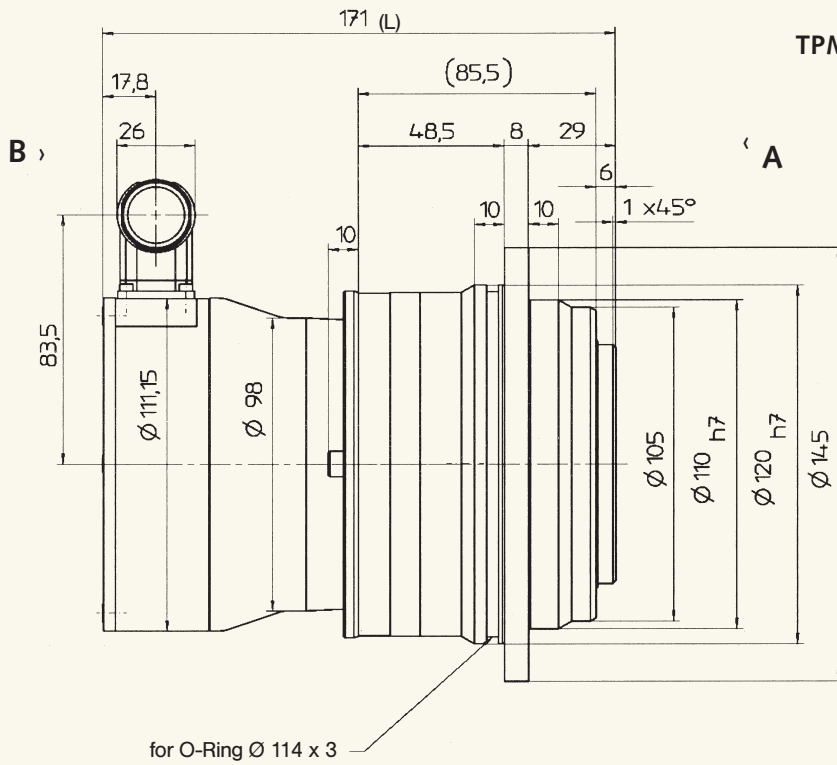

Standard version with resolver **with**  
brake at i=110/220

**TPMA 025-...R-.....-BP.-015**





Total length L for other options		
TPMA 025, i = 110, 220	Without brake	With brake
Heidenhain motor encoder	217	258.6
Stegmann motor encoder	213	241.6

View A

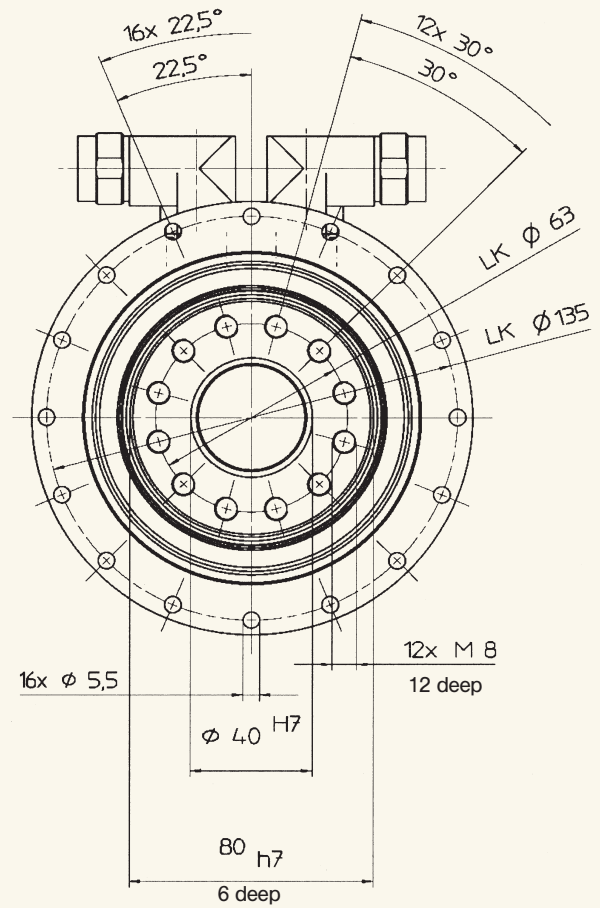

View B

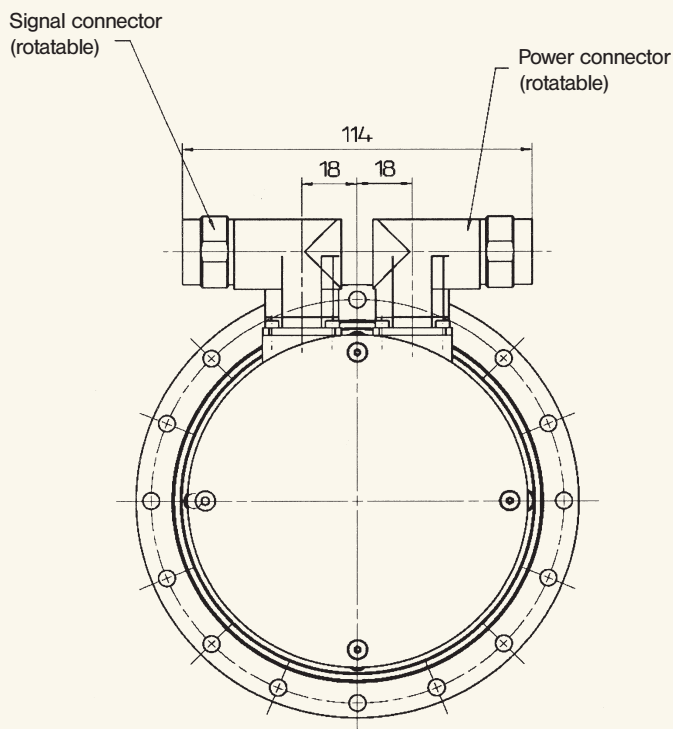

# TPMA 050 - Technical data, characteristic curves and drawings

## Gearhead data

Ratio	i			110, 220
Max. acceleration torque <sup>1)</sup>	$T_{2B}$	Nm		950
Emergency Stop torque <sup>2)</sup>	$T_{2Not}$	Nm		2,375
Nominal output torque	$T_{2N}$	Nm		675
Max. input speed	$n_{1Max}$	min <sup>-1</sup>		5,000
Nominal input speed <sup>3)</sup>	$n_{1N}$	min <sup>-1</sup>		2,600
Torsional backlash	$j_t$	arcmin		≤ 1
Torsional rigidity	$C_{t21}$	Nm/arcmin		186
Max. axial force <sup>4)</sup>	$F_{2AMax}$	N		6,130
Max. tilting torque	$M_{2TiltMax}$	Nm		1,295
Tilting rigidity	$C_{2K}$	Nm/arcmin		560
No-load running torque ( $n_1 = 3000 \text{ min}^{-1}$ ) <sup>5)</sup>	$T_{012}$	Nm		0.8
Moment of inertia reflected to the input	$J_{Gear}$	kgcm <sup>2</sup>	i = 110 i = 220	2.43 2.31

## Motor data

			i = 110, 220	
DC bus voltage	$U_D$	VDC	320	600
Peak torque <sup>6)</sup>	$M_{Max}$	Nm	7.80	7.80
Continuous stall torque	$M_0$	Nm	3.60	3.50
Nominal torque	$M_N$	Nm	2.80	2.50
Peak current <sup>6)</sup>	$I_{Max}$	A	19.60	13.70
Nominal current	$I_N$	A	4.20	2.60
No-load speed <sup>6)</sup>	$n_0$	min <sup>-1</sup>	5,000	5,900
Nominal speed <sup>6)</sup>	$n_N$	min <sup>-1</sup>	3,775	4,562
Max. power	$P_{Max}$	kW	2.25	2.53
Moment of inertia with resolver	$J_{Mot.}$	kgcm <sup>2</sup>	2.28	

## General data

Protection class		IP64
Operating temperature range	°C	-10 to +90
Mounting position		Any
Lubrication		Synthetic oil, ISO VG 220
Paint		RAL 5002 (Blue)
Noise level ( $n_1 = 3000 \text{ min}^{-1}$ )	dB(A)	≤ 70
Weight without/with brake	kg	17.6/18.8
Direction of rotation		motor and gearhead in same direction
Insulation class		F

1) 1000 cycles per hour

2) Permissible 1000 times during the life span of the gearhead

3) At 20°C ambient temperature

4) Based on the flange center

5) At 20°C gearhead temperature

6) Limit motor values to maximum values of the gearhead

The maximum and nominal values of the gearhead can limit the output values in some circumstances.

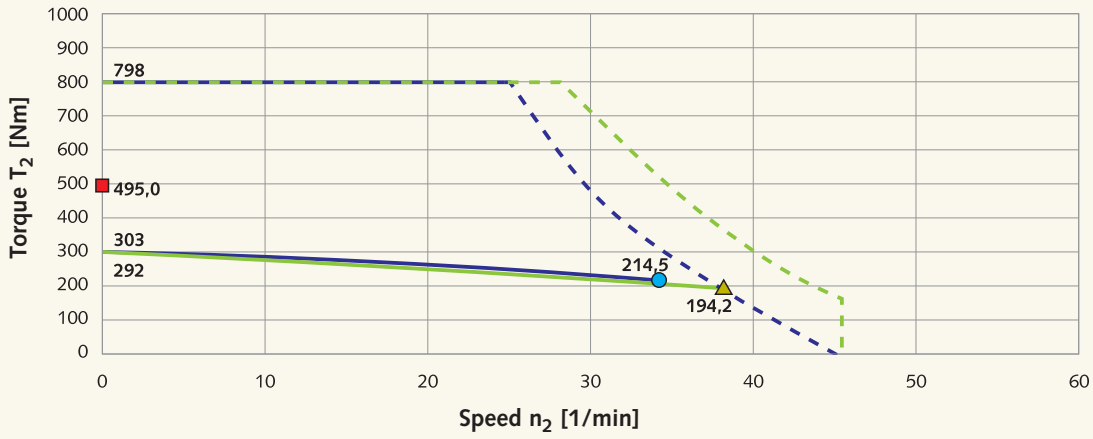

$i = 110$

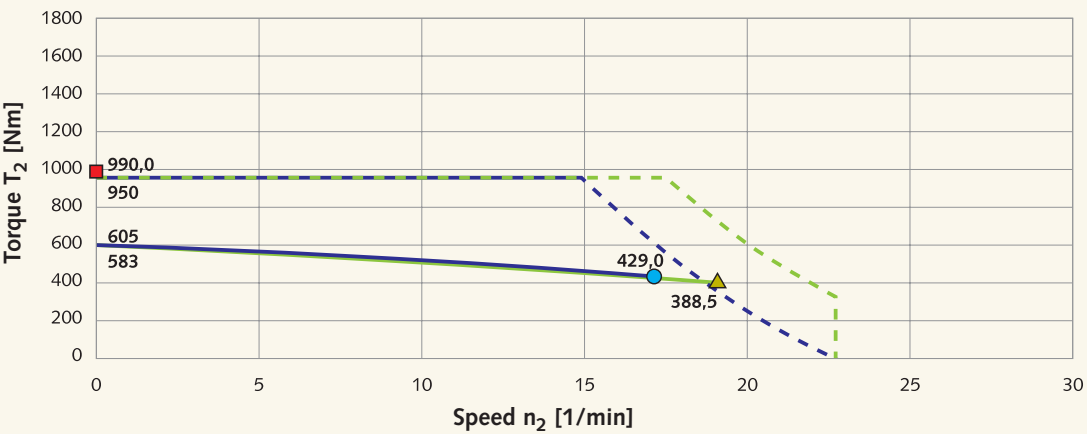

$i = 220$

- - - Max. output torque 320V DC
- Nominal torque 320V DC
- Holding torque: brake
- - - Max. output torque 600V DC
- Nominal torque 600V DC
- Nominal point 320V DC
- ▲ Nominal point 600V DC





Standard version with resolver **without** brake at  $i=110/220$

TPMA 050-...R-....-OH.-015

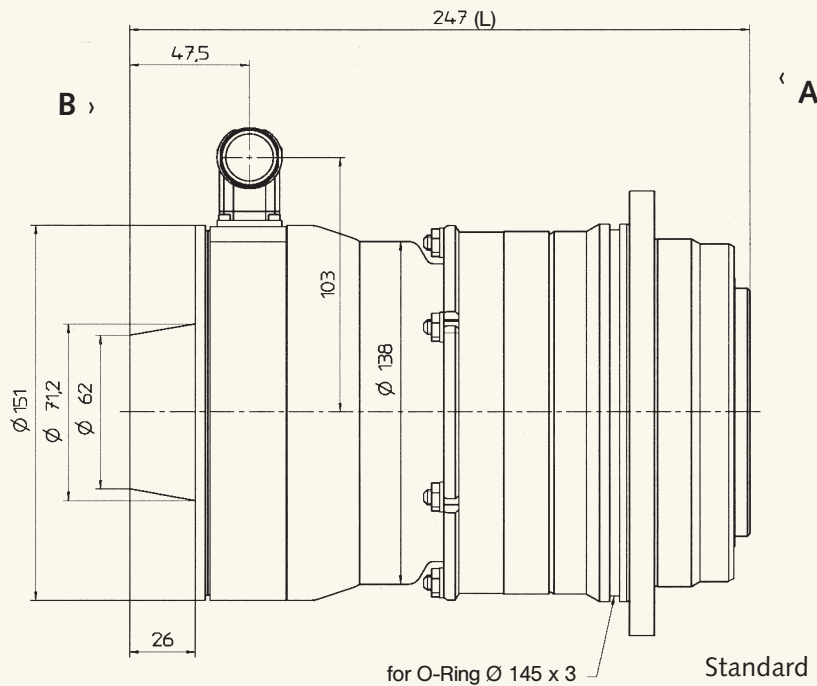
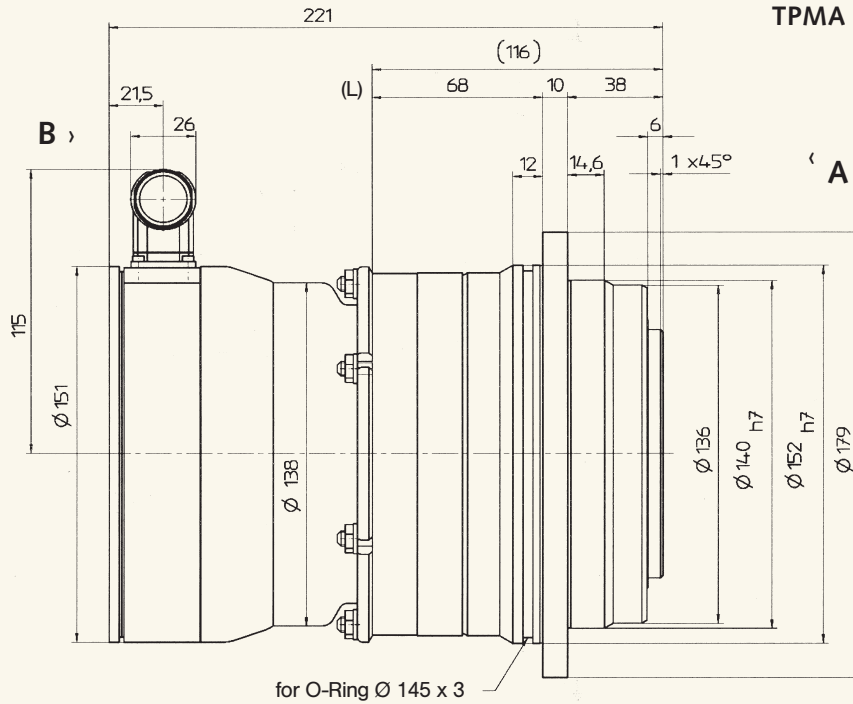

Standard version with resolver **with** brake at  $i=110/220$

TPMA 050-...R-....-OH.-015

Total length L for other options		
TPMA 050, i = 110, 220	Without brake	With brake
Heidenhain motor encoder	263	310
Stegmann motor encoder	263	292

View A

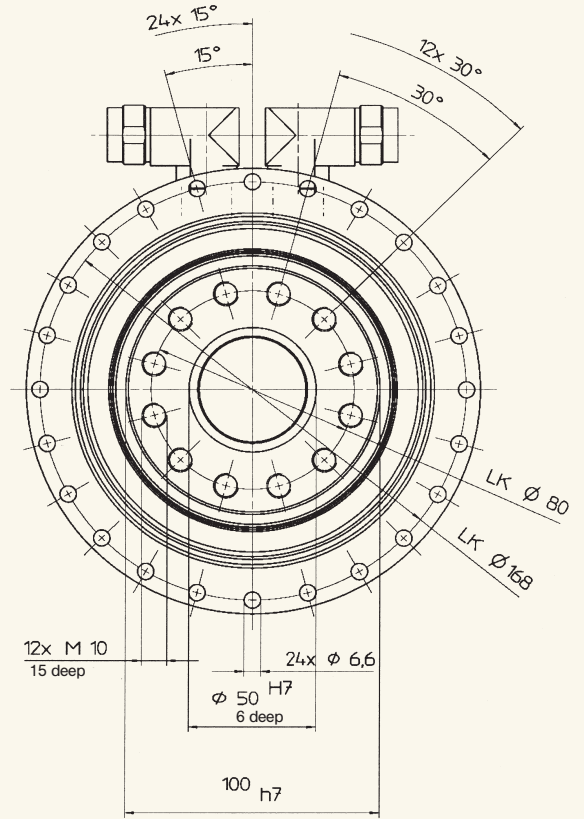

View B

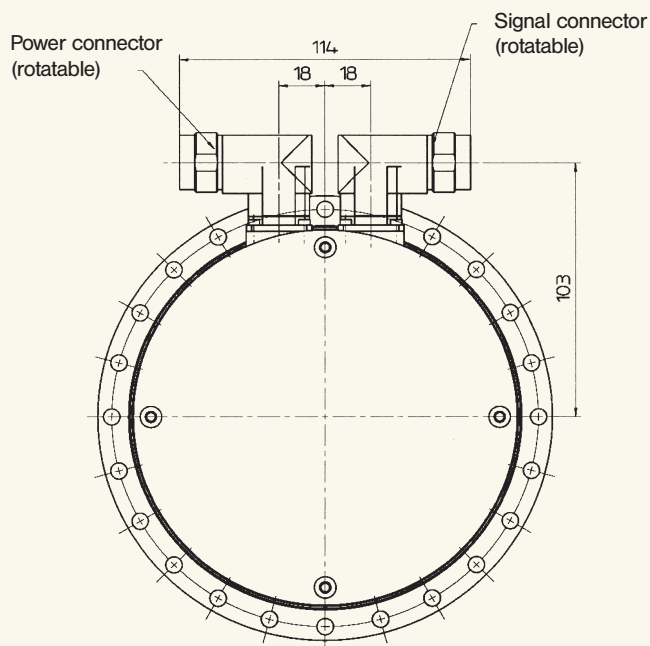



# TPMA 110 - Technical data, characteristic curves and drawings

## Gearhead data

Ratio	i			110, 220
Max. acceleration torque <sup>1)</sup>	$T_{2B}$	Nm		2,600
Emergency Stop torque <sup>2)</sup>	$T_{2Not}$	Nm		6,500
Nominal output torque	$T_{2N}$	Nm		1,570
Max. input speed	$n_{1Max}$	min <sup>-1</sup>		4,500
Nominal input speed <sup>3)</sup>	$n_{1N}$	min <sup>-1</sup>		2,100
Torsional backlash	$j_t$	arcmin		≤ 1
Torsional rigidity	$C_{t21}$	Nm/arcmin		550
Max. axial force <sup>4)</sup>	$F_{2AMax}$	N		10,050
Max. tilting torque	$M_{2TiltMax}$	Nm		3,064
Tilting rigidity	$C_{2K}$	Nm/arcmin		1,452
No-load running torque ( $n_1 = 3000 \text{ min}^{-1}$ ) <sup>5)</sup>	$T_{012}$	Nm		1.70
Moment of inertia reflected to the input	$J_{Gear}$	kgcm <sup>2</sup>	i = 110 i = 220	0.646 0.159

## Motor data

			i = 110, 220	
DC bus voltage	$U_D$	VDC	320	600
Peak torque <sup>6)</sup>	$M_{Max}$	Nm	30.50	32.60
Continuous stall torque	$M_0$	Nm	13.60	13.60
Nominal torque	$M_N$	Nm	6.60	4.90
Peak current <sup>6)</sup>	$I_{Max}$	A	75.00	54.00
Nominal current	$I_N$	A	12.40	5.60
No-load speed <sup>6)</sup>	$n_0$	min <sup>-1</sup>	6,380	7,180
Nominal speed <sup>6)</sup>	$n_N$	min <sup>-1</sup>	5,375	6,000
Max. power	$P_{Max}$	kW	11.18	13.00
Moment of inertia with resolver	$J_{Mot.}$	kgcm <sup>2</sup>	9.68	

## General data

Protection class		IP64
Operating temperature range	°C	-10 to +90
Mounting position		Any
Lubrication		Synthetic oil, ISO VG 220
Paint		RAL 5002 (Blue)
Noise level ( $n_1 = 3000 \text{ min}^{-1}$ )	dB(A)	≤ 70
Weight without/with brake	kg	43.6/46.0
Direction of rotation		motor and gearhead in same direction
Insulation class		F

1) 1000 cycles per hour

2) Permissible 1000 times during the life span of the gearhead

3) At 20°C ambient temperature

4) Based on the flange center

5) At 20°C gearhead temperature

6) Limit motor values to maximum values of the gearhead

The maximum and nominal values of the gearhead can limit the output values in some circumstances.

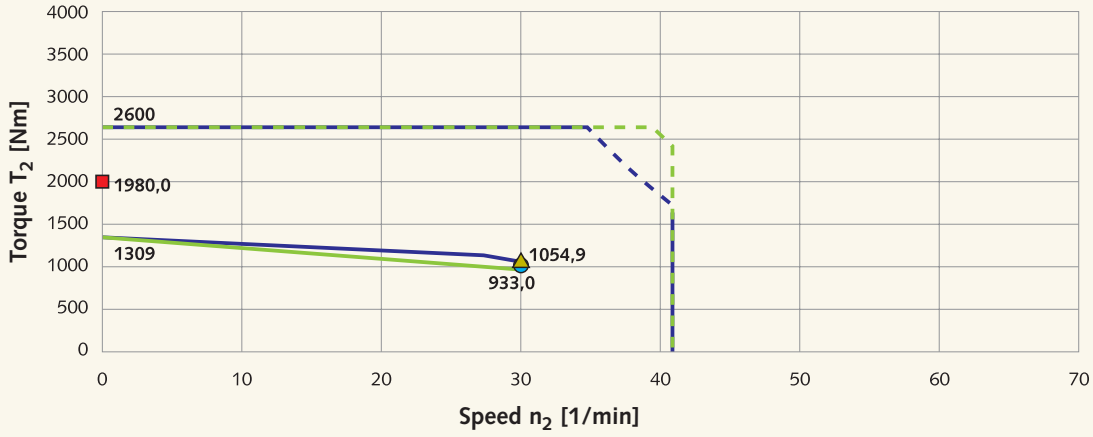

**i = 110**

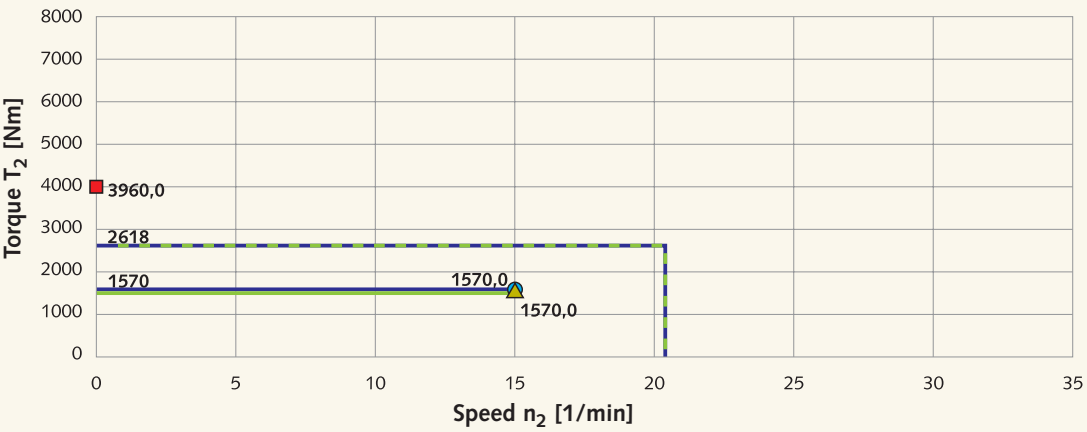

**i = 220**

- Max. output torque 320V DC
- Max. output torque 600V DC
- Nominal torque 320V DC
- Nominal torque 600V DC
- Holding torque: brake
- Nominal point 320V DC
- ▲ Nominal point 600V DC





Standard version with resolver **without** brake at  $i=110/220$

**TPMA 110-...R-....-OH.-060**

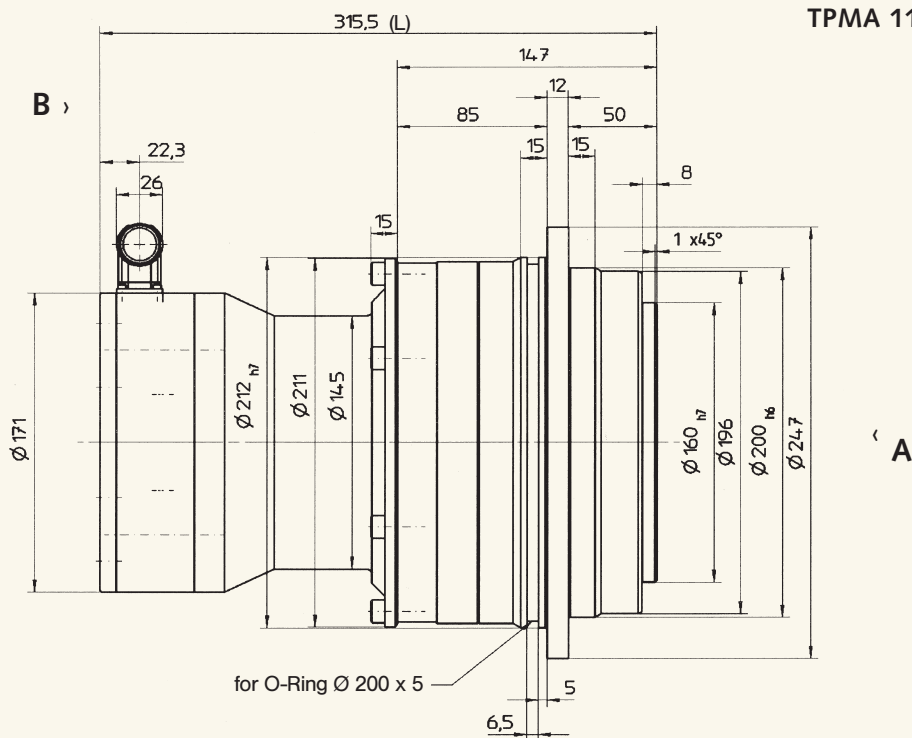

Standard version with resolver **with** brake at  $i=110/220$

**TPMA 110-...R-....-BP.-060**

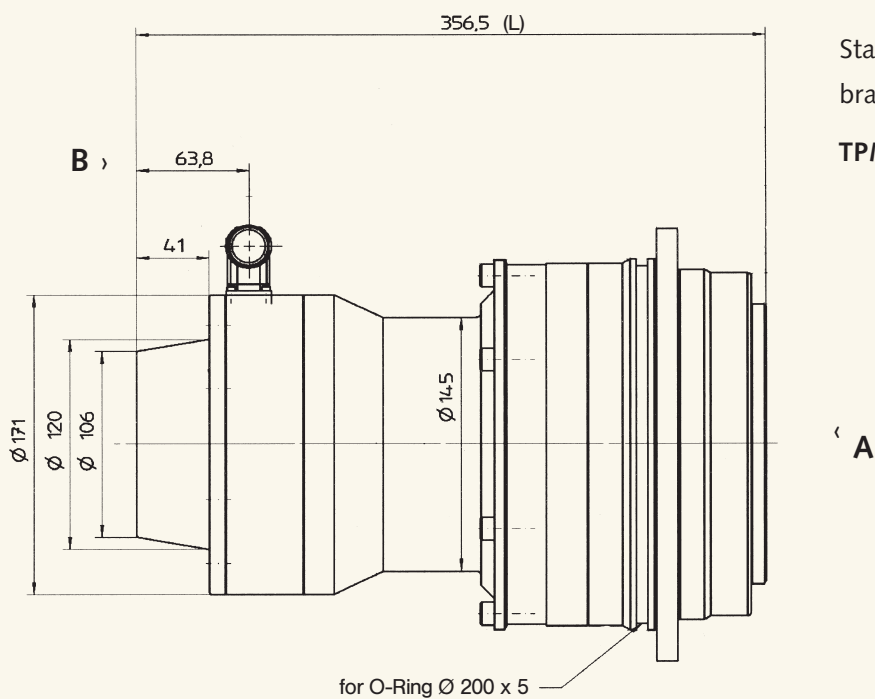





Total length L for other options		
TPMA 110, i = 110, 220	Without brake	With brake
Heidenhain motor encoder	356.5	420.5
Stegmann motor encoder	330.5	402.5

View A

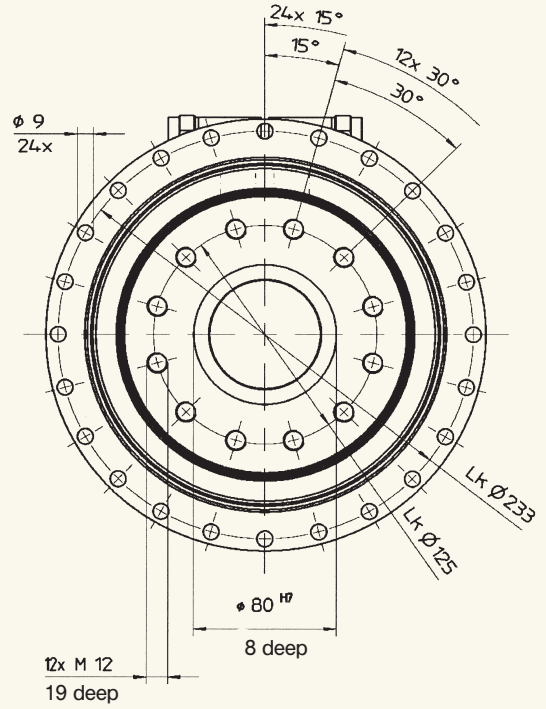

View B

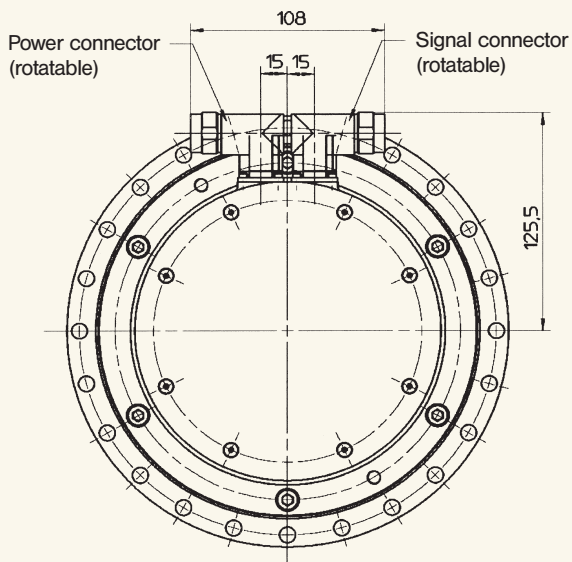

# Options

## Electrically-released holding brake

A compact permanent-magnet brake is available for holding the rotor when the power is off. It is characterized by backlash-free operation, drag-free when disengaged, unlimited ON time and constant torque at high operating temperatures.

Data		TPM 004 only with resolver	TPM 004	TPM 010, TPM(A) 025	TPM(A) 050 (i=61/91/110/220)	TPM(A) 110, TPM 050 (i=21/31)
Holding torque at 20°C	Nm		1	2	4.5	18
Holding torque at 100°C	Nm	0.4	0.8	1.8	4.0	15
Dynamic torque	Nm	-	0.8	1.7	3.8	15
Moment of inertia	kgcm <sup>2</sup>	-	0.021	0.068	0.18	1.66
Weight	kg	0.01	0.11	0.15	0.30	0.9
Release/set time	ms	0.05	12/8	25/6	35/7	50/10
Coil resistance at 20°C	Ω	27/13	53-62	48-56	45-51	22-26
Supply voltage	V DC	96			24 +6% -10%	
Current	A	0.25	0.45	0.55	0.54	1.1

## Temperature sensors

The following temperature sensors are available with various servo controllers. They measure temperature directly at the motor coil.

- PTC - Positive temperature coefficient thermistor
- KTY - Linear temperature coefficient thermistor
- NTC - Negative temperature coefficient thermistor

## Feedback systems

Various feedback systems are available for position encoding.

A single turn brushless resolver feedback is standard for TPM. This robust feedback device is suitable for many applications with normal demands for smooth running and precision.

For higher technical demands, optical encoders are available from Heidenhain and Stegmann. Using the EnDat® and Hiperface® interfaces, position values as well as information regarding startup and drive data can be stored to and retrieved from the TPM.

See page 46 for the respective pin assignments.

# Comparison of TPM feedback devices

Parameter	Unit	HEIDENHAIN			STEGMANN		Resolver
		ERN1387	ECN1313	EQN1325	SRS50/66K	SRM50/66K	
Encoder type		Incremental	Abs. Singleturn	Abs. Multiturn	Abs. Singleturn	Abs. Multiturn	Abs. Singleturn
Operating voltage	V	5	5	5	7 ... 12	7 ... 12	7 (10 KHz)
Data interface		-	EnDat	EnDat	Hiperface	Hiperface	-
Electronic type plate		-	3	3	3	3	-
Form of the incremental signals		$\sim$ 1 Vss	$\sim$ 1 Vss	$\sim$ 1 Vss	$\sim$ 1 Vss	$\sim$ 1 Vss	-
Number of sin/cos periods per revolution		2048	2048	2048	1024	1024	1
Reference track available		3	-	-	-	-	-
Absolute position when main power is on		3 (within 1 revolution)	3 (within 1 revolution)	3	3 (within 1 revolution)	3	3 (within 1 revolution)
Absolute resolution	Pos./rev	1 Sin/Cos period	8192	8192	32768	32768	1 Sin/Cos period
Multiturn function	Rev.	-	-	3	-	3	-
Multiturn measuring range		-	-	4096	-	4096	-
Max. operating temperature	°C	120	115	115	115	115	150
Min. operating temperature	°C	-30	-30	-30	-20	-20	-55
Moment of inertia	10 <sup>-2</sup> kgcm <sup>2</sup>	2,6	2,6	2,6	1	1	TPM 004 0,2 TPM (A)010-050 3 TPM 110 23,4



# Accessories

## Cables

Matching signal and power cables for the tested servo controllers listed on page 45 are available.

Please supply the following data when you order:

- Complete TPM description
- Desired length of cable, in 5 meter increments.
- Exact type description of servo controller to be used

The cables have excellent quality:

- Suitable for cable tracks, because highly flexible wires in accordance with DIN VDE 0295, class 6
- Oil and fire proof
- Free of halogen, silicon and CFC

## Mechanical characteristics:

Max. tensile strength	Static 50 N/mm <sup>2</sup> conductor diameter Dynamic 20 N/mm <sup>2</sup> conductor diameter
Max. permissible torsion	± 30°/m
Permissible operating temperature	Static: -50°C to +80°C Flexed: -20°C to +70°C
Min. permissible bending radius	10 x D (outer diameter of cable) k)
Number of bending cycles	5 million (at bending radius 10 x D)
Max. permissible acceleration	5 m/sec <sup>2</sup>
Max. permissible speed	180 m/min

k)		D	conductor diameter
Power cable	TPM 004 - TPM(A) 050 (i=61, 91, 110, 220)	12,2 mm	4 x 1,5 mm <sup>2</sup> + 2 x 0,75 mm <sup>2</sup>
	TPM 050 (i=21, 31), TPM(A) 110	15,1 mm	4 x 2,5 mm <sup>2</sup> + 2 x 1 mm <sup>2</sup>
Signal cable		10 mm	

# Servo controller

The TPM/TPMA AC servo actuators can be operated with a wide variety of servo controllers. The subsequent table listed all tested controllers with information on the correct option choices, feedbacks, temperature sensor and DC bus voltage.

For a number of these, a written startup manual is available. It contains all relevant parameter settings of the respective manufacturer to ensure that the startup can be performed in the shortest possible time.

Manufacturer	Series/type	feedback device				Temperature sensor			DC bus voltage		Cannot be implemented with TPM ...
		Resolver	Incremental	EnDat interface	Hiperface interface	PTC	NTC	KTY 84-130	320V DC	600V DC	
AMK <sup>2)</sup>	AMKKASYN KU	8	-	8	8	8	-	-	8	8	
Atlas Copco	DMC 2	8	-	-	-	8	-	-	8	8	
Berger Lahr <sup>2)</sup>	Twin Line	-	-	-	8	8	-	-	8	8	
Bosch <sup>2)</sup>	Servo Dyn D	8	-	8	-	-	8	-	-	8	004
B & R <sup>2)</sup>	AcoPos	8	-	8	-	8	-	8	-	8	004
CT <sup>1)</sup>	UniDrive	8	-	-	8	8	-	-	-	8	004
ESR Pollmeier	Trio-/Mididrive Digital	8	-	8	8	8	-	-	8	8	
Hauser Hannifin <sup>2)</sup>	Compax	8	-	-	8	8	-	8	8	8	
Bosch Rexroth	Ecodrive 03	8	-	8	-	8	-	-	8	8	004, 010
(Indramat) <sup>1)</sup>	Ecodrive 03, 16A	8	-	-	-	8	-	-	8	8	
	DIAX 04	8	-	8	-	8	-	-	8	8	004, 010
KEB <sup>1)</sup>	Combivert S4	8	8	-	-	8	-	-	8	8	
Lenze <sup>1)</sup>	Global Drive 93xx	8	-	-	8	8	-	8	-	8	004
Nord <sup>2)</sup>	SK 1000 E	8	-	-	-	-	-	8	-	8	004
Danaher Motion <sup>1)</sup> (Seidel Kollmorgen)	Servostar 600/400	8	-	8	8	8	-	-	8	8	
Siemens <sup>1)</sup>	SimoDrive 611U	8	8	8	-	-	-	8	-	8	004
	SimoDrive 611D/840D	-	8	8	-	-	-	8	-	8	004
	Master Drive MC	8	8	8	-	8	-	8	-	8	004
S.B.C. <sup>2)</sup>	HPD	8	-	-	-	8	-	-	8	8	
	LVD	8	-	-	-	8	-	-	8	-	

Information on additional controllers can be supplied on request.

8 = possible

- = not available

1) = Startup manual available

2) = Startup manual in preparation



# Plug connections

## Resolver, Singleturn

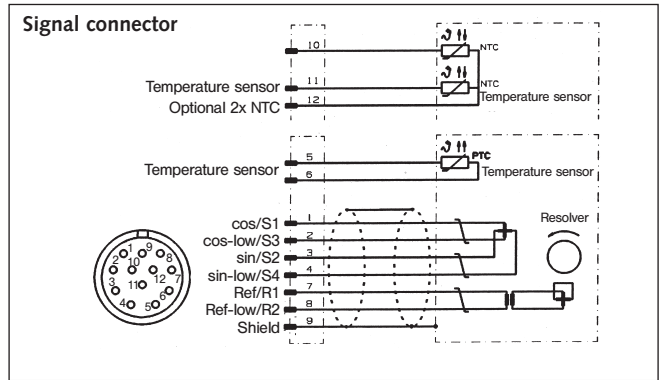
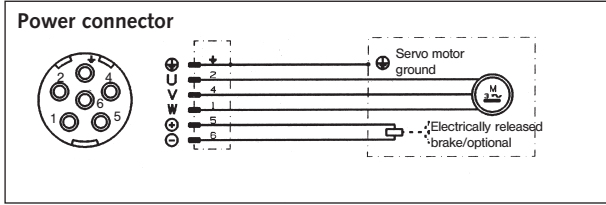

## Stegmann encoder, Single and Multiturn Hiperface®

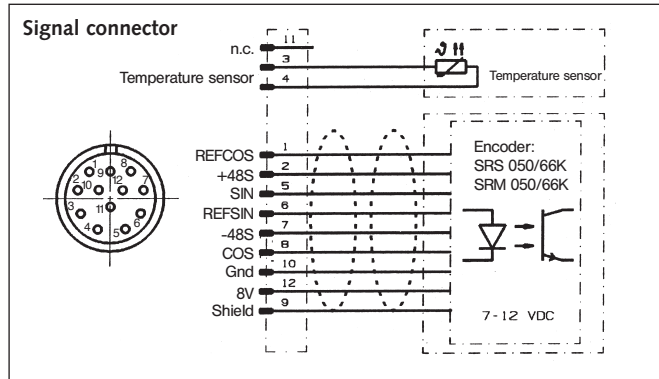
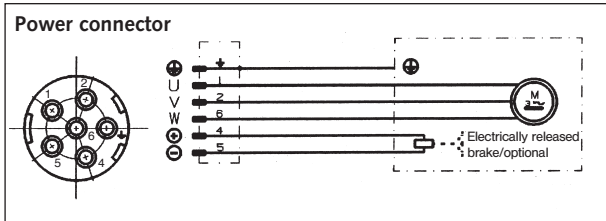

## Heidenhain encoder, Single- and Multiturn EnDat®

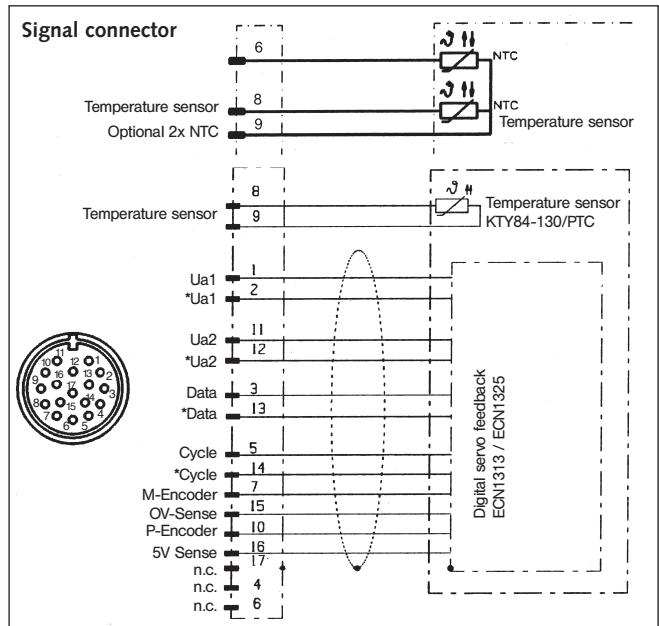
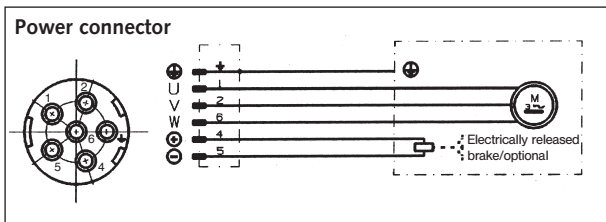

## Heidenhain encoder, incremental

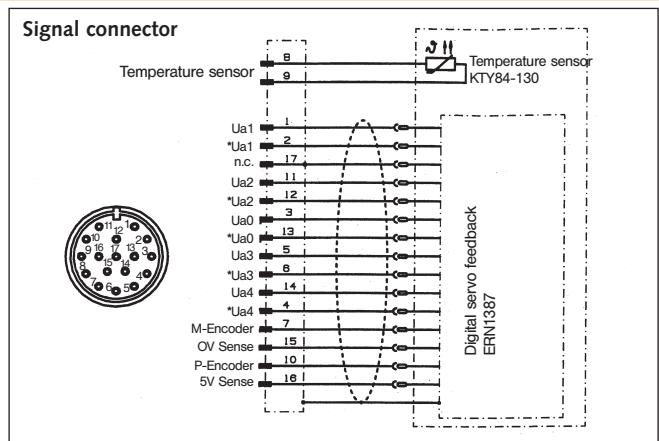
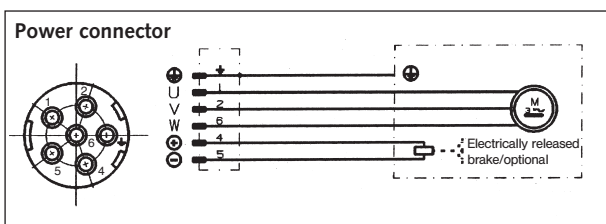

# Ordering codes

**TPM 025 - 021M - 600K - BP1**

**Size**

TPM 004 / 010 / 025 / 050 / 110  
 TPMA 025 / 050 / 110

**Ratio**

21 / 31 / 61 / 91 (TPM)  
 110 / 220 (TPMA)

**Motor encoder**

R = Resolver  
 S = Singleturn absolute encoder EnDat®  
 M = Multiturn absolute encoder EnDat®  
 N = Singleturn absolute encoder Hiperface®  
 K = Multiturn absolute encoder Hiperface®  
 I = Incremental encoder

**Backlash**

1 = Standard < 3 (5) arcmin  
 0 = Reduced < 1 (3) arcmin  
 (values in brackets: TPM 004)

**Brakes**

BP = Permanent magnet brake  
 OH = Without brake

**Temperature sensor**

P = PTC  
 N = NTC  
 K = KTY 84-130

**DC bus voltage**

320 = 320V DC at controller input  
 voltage 1x230V/3x230V AC  
 600 = 600V DC at controller input  
 voltage 3x400V AC

**Additional options without codes**

- Straight plug connections
- Painted in RAL 9005 (black)
- Synthetic oil, ISO PG68
- UL approbation
- Explosionproof model (on request)



## WMC-Vertriebsorganisation / WMC-Sales organisation

<b>D</b>	<b>WITTENSTEIN motion control GmbH</b> Walter-Wittenstein-Str. 1 97997 Igersheim · Germany	Tel. +49 (0) 79 31/4 93-0 Fax +49 (0) 79 31/4 93-2 00 E-Mail info@w-m-c.de http://www.w-m-c.de	<b>F</b>	<b>alpha réducteurs Sarl</b> 85, rue Galliéni F - 95170 Deuil la Barre	Tel. +33 (0) 1/34 17 90 95 Fax +33 (0) 1/39 83 66 23
<b>D</b>	<b>Service:</b> alpha getriebebau GmbH Walter-Wittenstein-Str. 1 97999 Igersheim · Germany	Tel. +49 (0) 79 31/4 93-0 Fax +49 (0) 79 31/4 93-2 00 E-Mail service@alphagetriebe.de	<b>FIN</b>	<b>Kontram OY</b> P.O. Box 88 FIN - 02201 Espoo	Tel. +358 (0) 9/88 66 45 00 Fax +358 (0) 9/88 66 47 99
<b>D</b>	<b>Technisches Büro Walluf</b> Kapellenstr. 5 D - 65396 Walluf	Tel. +49 (0) 61 23/99 05 30 Fax +49 (0) 61 23/99 05 31	<b>GB</b>	<b>alpha gearheads Ltd.</b> The Big House,1 Moorland Road, Burslem GB-Stoke-on-Trent Staffordshire ST6 1DJ	Tel. +44 (0) 87 08/44 01 20 Fax +44 (0) 87 08/44 01 40 E-Mail: sales@alphagearheads.com http://www.alphagearheads.com
<b>D</b>	<b>Technisches Büro Nord</b> Bahnhofstr. 62 D - 31812 Bad Pyrmont	Tel. +49 (0) 52 81/98 98 - 0 Fax +49 (0) 52 81/98 98 - 60	<b>GR</b>	<b>alpha motion</b> Alkamenoy's Street 5-7 GR - 10439 Athens	Tel. +30 (0) 1/8 22 74 70 Fax +30 (0) 1/8 25 37 87
<b>D</b>	<b>Technisches Büro Süd-West</b> Seestraße 6 D - 71638 Ludwigsburg	Tel. +49 (0) 71 41/90 16 93 Fax +49 (0) 71 41/90 17 04	<b>I</b>	<b>alpha riduttori S.p.A.</b> Via Lodovico Ariosto, 13 I - 20091 Bresso (Milano)	Tel. +39 02/66 52 81-1 Fax +39 02/66 52 81-30
<b>D</b>	<b>Technisches Büro Süd-Ost</b> Baiermühle 3 D - 73441 Bopfingen	Tel. +49 (0) 73 62/91 92 76 Fax +49 (0) 73 62/91 92 77	<b>IL</b>	<b>Medital Hi-Tech (1992) Ltd.</b> 7 Leshem St. P.O.B. 7772 Petach Tikva 49170 IL - Ramat SIV	Tel. +972 (0) 3/9 23 33 23 Fax +972 (0) 3/9 22 82 88
<b>D</b>	<b>Technisches Büro West</b> Königshardt Straße 103 D - 46145 Oberhausen	Tel. +49 (0) 2 08/62 88 66 Fax +49 (0) 2 08/62 88 67	<b>J</b>	<b>alpha getriebe Ltd.</b> 2-20-13 Higashinakano, Nakano-ku, J-Tokyo 164-0003	Tel. +81 (0) 3/32 27 83 50 Fax +81 (0) 3/32 27 83 51
<b>D</b>	<b>Technisches Büro Ost</b> Lungwitzer Str. 91a D - 09356 St. Egidien	Tel. +49 (0) 37 20/4 52 11 Fax +49 (0) 37 20/4 52 81	<b>MEX</b>	<b>URANY S.A. de C.V.</b> Mecanicos # 53, Col. Penuelas Querétaro Qro. MEX - Mexico 76148	Tel. +52 (0) 42/20 90 89 Fax +52 (0) 42/20 96 46
<b>D</b>	<b>Technisches Büro Mitte</b> Händelstraße 20 D - 04288 Leipzig	Tel. +49 (0) 3 42 97/1 67 29 Fax +49 (0) 3 42 97/1 67 30	<b>N</b>	<b>Transtech A/S</b> Lagaveien 5, N - 3262 Larvik	Tel. +47 (0) 33/14 06 00 Fax +47 (0) 33/14 06 01
<b>A</b>	<b>alpha getriebe GmbH</b> Aredstrasse 11-13 A - 2544 Leobersdorf	Tel. +43 (0) 22 56/6 56 32-0 Fax +43 (0) 22 56/6 56 32-33	<b>P</b>	<b>Equinotec SA</b> Av. Villagarcia de Arosa, 1120 P - 4450-300 Matosinhos	Tel. +351 (0) 2 29/35 07 55 Fax +351 (0) 2 29/35 10 24
<b>AUS</b>	<b>Numericon PTY. Ltd.</b> 115 Bath Road Kirrawee, NSW. 22 32 AUS - Sydney	Tel. +61 (0) 2/95 21 84 66 Fax +61 (0) 2/95 21 48 04	<b>PL</b>	<b>WAMEX Co. Ltd. Sp. z.o.o.</b> ul. Pozaryskiego 28 PL - 04-703 Warszawa	Tel. +48 (0) 22/6 15 90 80 Fax +48 (0) 22/6 15 90 81
<b>B/L</b>	<b>alpha Benelux B.V.B.A.</b> Ambachtenlaan 6A B - 9080 Lochristie	Tel. +32 (0) 9/3 26 73 80 Fax +32 (0) 9/3 45 48 13	<b>RA</b>	<b>E.R.H.S.A.</b> Girardot 1368 RA - 1427 - Capital Federal	Tel. +54 (0) 11/45 54-32 32 Fax +54 (0) 11/45 52-36 11
<b>BR</b>	<b>AUTOMOTION Ltda.</b> Acesso Jose Sartorelli, Km 2.1 CEP 18550-000 BR - Boituva-SP	Tel. +55 (0) 15/33 63 99 00 Fax +55 (0) 15/33 63 99 11	<b>ROC</b>	<b>RUN ACE Co. Ltd.</b> No. 2, Lane 137, Sec. 2, Pa Te Rd. ROC - Taipei, Taiwan	Tel. +886 (0) 2/27 73 18 85 Fax +886 (0) 2/27 51 11 16
<b>CDN</b>	<b>alpha gear drives</b> 21, Pamela Street CDN - Waterdown, Ontario L0R 2H3	Tel. +1 (0) 9 05/6 90 70 86 Fax +1 (0) 9 05/6 90 70 84	<b>ROK</b>	<b>FAtec Co. Ltd.</b> #903, Sunglim B/D 257 Chulsan-Dong, Kwangmyung-City ROK-Kyunggi-Do, Korea	Tel. +82 (0) 2/26 88 21 52 Fax +82 (0) 2/26 88 28 42
<b>CH</b>	<b>WITTENSTEIN AG Schweiz</b> Usserfeld (Postfach 29) CH - 7214 Grösch	Tel. +41 (0) 81/3 30 33 80 Fax +41 (0) 81/3 30 33 83	<b>S</b>	<b>alpha drives ab</b> Regementsgatan 52 C S - 21748 Malmö	Tel. +46 (0) 40/26 50 10 Fax +46 (0) 40/26 50 09
<b>CZ</b>	<b>Consenta spol. s.r.o.</b> Hellichova c. 1 CZ - 110 00 Praha - 1	Tel. +42 (0) 2/57 32 24 82 Fax +42 (0) 2/57 32 24 83	<b>SGP</b>	<b>Colben System Pte Ltd</b> 65 Joo Koon Circle SGP - Singapore 629078	Tel. +65 /66 65 53 77 Fax +65 /66 65 53 11
<b>DK</b>	<b>HANO ELEKTROTEKNIK A/S</b> Ove Gjeddes Vej 9b DK - 5220 Odense SØ	Tel. +45 (0) 63/15 30 60 Fax +45 (0) 63/15 30 70	<b>USA</b>	<b>alpha gear drives, Inc.</b> 1440 Howard Street USA - Elk Grove Village, IL 60007	Tel. +1 (0) 8 47/4 39 07 00 Fax +1 (0) 8 47/4 39 07 55
<b>E</b>	<b>S.A. Sistel</b> Santanac, 25 E - 08206 Sabadell (Barcelona)	Tel. +34 (0) 93/7 27 00 74 Fax +34 (0) 93/7 25 35 76	<b>ZA</b>	<b>Flexible Electronic Systems (PTY) Ltd.</b> 27 Forge Road, Spartan ZA - Kempton Park 16 20	Tel. +27 (0) 11/ 9 75-70 00 Fax +27 (0) 11/ 3 94-20 85